



VX4520
Resource Manager Module
Operating Manual

08/20/92

9103-01-D
through
9208-01-E

Tektronix

WARRANTY

This Tektronix, Inc. product is warranted against defects in materials and workmanship, and is warranted to meet the performance specifications as listed in the current catalog and/or data sheet for this product. This warranty applies for three (3) years following the date of shipment. Tektronix will, at its option, repair or replace, at no cost to the customer, this product should it prove to be defective during the warranty period, provided the defect or failure is not due to misuse or abuse of the product. The customer is responsible for shipment of the defective product to the Tektronix repair facility. NO OTHER WARRANTY IS EXPRESSED OR IMPLIED, INCLUDING WARRANTY FOR FITNESS OF PURPOSE. TEKTRONIX INC. SHALL, IN NO CASE, BE LIABLE FOR CONSEQUENTIAL DAMAGES.

TRADEMARK NOTIFICATION

VXIbus is a trademark of the VXI Consortium.

All other brand and product names are trademarks or registered trademarks of their respective companies.

© Copyright 1992 by
Colorado Data Systems, Inc.
A Subsidiary of Tektronix
Englewood, CO 80110
All rights reserved.

Printed in U.S.A.

All commands terminate with a <CR> <LF> .

- BNO** BNO LA - issues the Begin Normal Operation command to the indicated device. (3 - 14)
- BUSTIME** modifies the IEEE-488 bus settling time. (3 - 15)
- BUSTIME?** returns the current GPIB bus settling time. (3 - 16)
- DLAD?** DLAD? - returns a list of the logical addresses for all devices in the VXI system. (3 - 17)
- DLIS?** DLIS? (LA) - returns information on the devices in the VXI system. (3 - 18)
- DNUM?** DNUM? - returns the number of devices in the VXI system. (3 - 23)
- ENO** ENO LA - issues the End Normal Operation WSP command to the indicated device. (3 - 24)
- GRANT** GRANT CommanderLA ServantLA - the servant device at logical address ServantLA will be granted to the commander device at logical address CommanderLA. (3 - 25)
- HDLLINE** HDLLINE LA Handler - returns the VME IRQ line associated with the specified interrupt Handler on device LA. (3 - 26)
- HDLMATRIX** HDLMATRIX - returns the interrupt handler matrix maintained internally by the Resource Manager. (3 - 27)
- HELP** HELP (Cmd) - returns help information on the user interface commands the Resource Manager interprets. (3 - 28)
- INTLINE** INTLINE LA Interrupter - returns the VME IRQ line associated with the specified Interrupter on device LA. (3 - 29)
- INTMATRIX** INTMATRIX - returns the interrupter matrix table maintained internally by the Resource Manager. (3 - 30)
- LOCK** LOCK LA ('CLEAR') - sends the WSP commands Set Lock or Clear Lock to the indicated VXIbus device. (3 - 31)
- MAP** MAP LA IEEEAdr - specifies a particular IEEE-488 address to be associated with a particular Logical Address. (3 - 32)
- READHDLS** READHDLS LA - returns the number of interrupt lines the device at LA may handle simultaneously. (3 - 33)

- READINTS** READINTS LA - returns the number of interrupt lines the device at LA may drive simultaneously. (3 - 34)
- RED** RED z₁ z₂ z₃ z₄ z₆ - reads VME memory space. (3 - 35)
- RELEASE** RELEASE CommanderLA ServantLA - the servant device at logical address ServantLA is released from the commander device at logical address CommanderLA.
- RESET** RESET (LA) ('SAFE') - resets a selected VXI device. (3 - 38)
- SETHDL** SETHDL LA Handler IRQ (send) - updates the Interrupt Handler Matrix table in the Resource Manager. (3 - 40)
- SETINT** SETINT LA Interrupter IRQ (send) - allows the Interrupter Matrix table in the Resource Manager to be modified and optionally cause the interrupt hierarchy to be modified to match the matrix. (3 - 42)
- SRQ** SRQ ('CLEAR') - enables or disables the generation of IEEE-488 SRQs whenever the VX4520 detects an error. (3 - 44)
- STATUS** STATUS (LA) - returns the current error status of a VXI device. (3 - 45)
- TABLE** TABLE - directs the VX4520 to return the number of devices and configuration information for each device in the mainframe which it controls. (3 - 46)
- TEST** TEST - causes the VX4520 to execute its built-in self test routine. (3 - 49)
- TIMEOUT** TIMEOUT (z) - assigns the amount of time the VX4520 waits for the assertion of the Read Ready and/or Write Ready bits in a device's Response register during WSP data transfers. (3 - 50)
- WRT** WRT z₁ z₂ z₃;Data - writes to VME memory space. (3 - 51)
- WSCMD** WSCMD LA CMD - sends the specified WSP command to a VXI device. (3 - 53)
- WSCMD?** WSCMD? LA CMD - sends the specified WSP command to a VXI device. The response value is returned in ASCII decimal format. (3 - 54)

ERROR HANDLING

When the VX4520 detects an operational error, it invokes an error message format routine that generates an appropriate ASCII message. The error message can be read by requesting input from the VX4520. Error messages and their meanings are detailed on p. 3 - 55.

An error message will overwrite any command result data that may already be present in the buffer, except another error message. Successive error messages are stored in the buffer until the buffer becomes full (buffer holds approximately ten error messages). Once the buffer is full, subsequent error messages are lost.

VX4520 MODULE QUICK REFERENCE GUIDE

Numbers in parentheses refer to the page(s) in the Operating Manual.

SETUP

Be sure all switches are correctly set. (p. 1 - 3)
Follow Installation guidelines. (p. 2 - 1)

LEDs

When lit, the LEDs indicate the following:

POWER	power supplies are functioning
SYSFAIL	module failure
ACCESS	the VX4520 is either accessing the VMEbus as a master or is currently being accessed as a VMEbus slave.
BUS ACCESS	indicates VMEbus activity; lit whenever any type of VMEbus cycle is in progress.
LISTEN	a device in the chassis is addressed as a listener on the IEEE-488 bus.
TALK	a device in the chassis is addressed as a talker on the IEEE-488 bus.
SRO	the SRQ (service request) line on the IEEE-488 bus is set true.
ATTN	the ATN (attention) line on the IEEE-488 bus is set true.
REMOTE	the REN (Remote Enable) line on the IEEE-488 bus is set true.

VXI USER INTERFACE COMMANDS

When the VX4520 is addressed as a Listener on the IEEE-488 bus, it will recognize certain ASCII strings that will cause an action to occur or cause a response to be formatted and returned to the IEEE-488 controller the next time the VX4520 is addressed as a Talker on the bus.

The syntax and symbols used in the command descriptions are:

()	optional parameter
{ }	group of parameters
...	optional repetition
<CR>	carriage return (decimal 13). Its use is host-specific and it may not be required as a terminator. Consult the host's Operating Manual.
<LF>	line feed (decimal 10). Its use is host-specific and it may not be required as a terminator. Consult the host's Operating Manual.
white space	blank and comma, used to separate fields in a command containing multiple parameters.
LA	logical address (1 - 255) of the VXibus device to receive the command, in either ASCII decimal or hex notation. If an ASCII hex number is used, it must be preceded by '#H' or '#h'.

Table of Contents

Section 1

General Information and Specifications

Introduction	1 - 1
Module Functions	1 - 1
New Features	1 - 2
Controls And Indicators	1 - 3
Switches	1 - 3
Fuses	1 - 6
LEDs	1 - 6
Specifications	1 - 9

Section 2

Preparation For Use

Installation Requirements And Cautions	2 - 1
Installation Procedure	2 - 2
Installation Checklist	2 - 3

Section 3

Operation

Overview	3 - 1
Power-up	3 - 1
Module Operation	3 - 2
Resource Manager	3 - 2
Slot 0 Functions	3 - 4
IEEE-488 Interface Device	3 - 4
VMEbus System Functions	3 - 6
IEEE-488 Control Lines	3 - 7
IEEE-488 Bus Commands	3 - 8
System Operation	3 - 10
Command Summary	3 - 10
Command Description Syntax	3 - 12
VXI User Interface Commands	3 - 14
Error Handling	3 - 55

Section 4

Programming Examples

Definition of BASIC Commands	4 - 1
Programming Examples In BASIC	4 - 2

Table of Contents - Continued

Appendix A - VXIbus Operation	A - 1
Appendix B - Input/Output Connections	A - 5
Appendix C - VXI Glossary	A - 7
Appendix D - Shifting Method	A - 15

List of Illustrations

Figure 1: VX4520 Controls and Indicators	1 - 8
Figure 2: Module Installation	2 - 2
Figure 3: Typical System Hierarchy	3 - 4

Operators Safety Summary

The general safety information in this summary is for both operating and servicing personnel. Additional specific warnings and cautions are found throughout the manual where they apply, and may not appear in this summary.

TERMS

In This Manual

WARNING statements identify conditions or practices that could result in personal injury or loss of life.

CAUTION statements identify conditions or practices that could result in damage to the module or other property.

Marked on the Module

DANGER indicates a personal injury hazard immediately accessible as one reads the marking.

CAUTION indicates a personal injury hazard not immediately accessible as one reads the marking, or a hazard to property, including the module itself.

SYMBOLS

In This Manual



This symbol indicates where applicable cautionary or other information is to be found.



This symbol indicates where special explanatory information is included in the manual. There is no caution or danger associated with the information.

Marked on the Module



DANGER — High Voltage.



Protective ground (earth) terminal.



ATTENTION — Refer to the manual.



Refer to manual before using.

Power Source

This module is intended to operate in a mainframe whose power source does not apply more than 250V rms between the supply conductors or between either supply conductor and ground. A protective ground connection through the grounding conductor in the power cord(s) is essential for safe operation.

Grounding the Module

This module is grounded through the grounding conductor of the mainframe power cord(s). To avoid electrical shock, plug the mainframe power cord(s) into a properly wired receptacle before connecting to the module connectors. A protective ground connection through the mainframe is essential for safe operation.

Danger Arising from Loss of Ground

Upon loss of the protective-ground connection, all accessible conductive parts can render an electric shock.

Use the Proper Fuse

To avoid fire hazard, use only fuses specified in the module parts list. A replacement fuse must meet the type, voltage rating, and current rating specifications required for the fuse that it replaces.

Do Not Operate in Explosive Atmosphere

To avoid explosion, do not operate the module in an explosive atmosphere.

Do Not Remove Covers or Panels

To avoid personal injury, the module covers should be removed only by qualified service personnel. Do not operate the module without covers and panels properly installed.

VX4520

Resource Manager Module

Section 1

General Information and Specifications

Introduction

The VX4520 Resource Manager Module is a printed circuit board assembly for use in the slot 0 position of a mainframe conforming to the VXIbus Specification, such as the VX1400 C size mainframe used in the Tektronix/CDS IAC System. It conforms to the VXIbus System Specification for a Resource Manager, Slot 0 Device, and IEEE-488 Interface Device for a C size module. The VX4520 performs three functions critical to the proper operation of a VXIbus system:

- 1) it is the VMEbus system controller required by the VMEbus Specification;
- 2) it provides both the VXIbus Resource Manager and Slot 0 functions required by the VXIbus Specification;
- 3) it acts as the communications interface between the station computer and the VXIbus chassis (VX1400 Mainframe) using the IEEE-488 General Purpose Interface Bus (GPIB).

Module Functions

As the VMEbus Controller, the VX4520 Module provides the bus arbiter, interrupt daisy chain driver, bus time out, system clock driver, power up reset, and system reset driver functions. It is also a VMEbus master. Since the VX4520 makes all VMEbus operations transparent to the user, no VMEbus knowledge is necessary to operate the VX4520 or any VXIbus system in which it is installed. The IEEE publication IEEE 1014 (1987) offers more information on VMEbus operation.

The Resource Manager portion of the Module is a VXIbus message based instrument located at logical address 0. After a maximum five second delay following power-up or system reset to allow individual VXIbus devices time to perform any required setups and self tests, the Resource Manager initializes the system and identifies all VXIbus devices in the system. It then builds a configuration table that contains status information for each device, including self test pass/fail results, slot location, manufacturer ID, model code, and other system information. The table may be up-loaded to the station controller through the IEEE-488 interface. The Resource Manager also configures system address maps, sets up the commander/servant hierarchies for the system, and then initiates normal system operation.

The VX4520 Resource Manager conforms to the VXIbus Specification Version 1.3 and can support VXI devices implementing either the 1.2 or the 1.3 version of the VXIbus Specification.

The slot 0 functions include a 10 MHz differential ECL clock driver for the backplane (CLK10), and transceivers for the MODID lines.

The IEEE-488 Interface Device portion of the VX4520 Module is a VXIbus message based commander that converts IEEE-488 protocol to VXIbus instrument protocol. It routes the incoming IEEE-488 instructions and data to the proper VXIbus instrument module in the mainframe and returns instrument responses to the IEEE-488 bus controller. It can also be switch selected to allow the VXIbus system to either assign each instrument module its own IEEE-488 primary address (multiple primary addressing), or to assign the overall system a single IEEE-488 address and each of the instrument modules a secondary address (single primary with multiple secondary addresses).

The VX4520 Module will execute a self test at power-up, on direction of a VXIbus hard reset, or on command. A VXIbus hard reset occurs when the Reset switch on the module's front panel is depressed, asserting the backplane line SYSRST*. The VX4520 can initiate a VXIbus soft reset in any VXIbus module in the chassis under command of the system controller.

New Features

The VX4520 offers a number of improvements over its predecessors. Foremost among these new features is full support for VXIbus Version 1.3 devices. The VX4520 also provides an expanded set of commands which allows more complete control of test systems. These commands are extensions to VXIbus requirements and are in addition to normal IEEE-488 operation (the default mode). They provide the more experienced user with important additional capabilities, including the ability -

- ▶ to reconfigure the default Commander/Servant hierarchy;
- ▶ to dynamically reconfigure the interrupt matrix;
- ▶ to move a device from one VXIbus-defined matrix to another; and
- ▶ to use timeouts to control the length of time the VX4520 polls for Read and/or Write Ready bits during Word Serial Protocol communication.

Information about the system and the devices in the system is easy to obtain under program control. In addition to operating parameters, you can determine: device logical address, device commander's logical address, manufacturer ID, model code, slot number, slot 0 logical address, device class, memory space, memory offset, memory size, pass/fail, manufacturer specific comments (if any), device IEEE address, VXIbus support information, and VXIbus Operational State.

The improved VX4520 also includes an extended Help facility that returns information on a specific command or on all the user interface commands provided by the Resource

Manager. The Quick Reference Guide included with this manual also lists the commands, and gives page references to the complete descriptions in the manual.

The scope of the error messages has been extended to include all aspects of its operation as a Resource Manager, an IEEE-488 interface, a VMEbus controller, and a slot 0 device. When the VX4520 detects the occurrence of an operational error, it invokes an error message format routine that generates an appropriate ASCII message for retrieval by the system controller when the Resource Manager is addressed to talk on the IEEE-488 bus.

An error message will overwrite any message that may already be in the Resource Manager output buffer, except for another error message. Successive error messages are appended onto one another until the buffer becomes full, thus building an error history. This can be extremely useful in tracking complex or elusive faults.

The VX4520 can be programmed to generate IEEE-488 Service Requests whenever an error occurs, which also helps in the detection of intermittent errors.

Controls And Indicators

The following controls and indicators are provided to select and display the functions of the VX4520 Module's operating environment. See Figure 1 for their physical locations.

Switches

Logical Address Switches

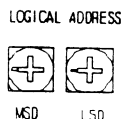

The VX4520 has two hexadecimal rotary switches which determine the VXIbus logical address for the IEEE-488 interface device. The IEEE-488 interface device is a VXIbus message based instrument which is the top level commander of all instruments in the mainframe. As such, it provides the full set of Configuration and Communication registers defined by the VXIbus Specification, including the Signal register.

The logical address of the VX4520 is used to define either the primary IEEE-488 address of the mainframe and/or the IEEE-488 address of the VXIbus Resource Manager. This is discussed more fully in the paragraph on the Configuration switch.

The base VMEbus address of the interface device is on a 64 byte boundary set by the two hexadecimal rotary switches. Align the desired switch position with the arrow on the module shield. If the switch representing the most significant digit (MSD) of the 64 byte page is set to position X and the switch representing the least significant digit (LSD) of the 64 byte page is set to position Y, then the base physical address of the Interface device will be $[(64d * XYh) + 49152d]$. For example:

	M	L	
L.	S	S	Base Physical
A.	D	D	Addr. (d)
Ah	0	A	$(64 * 10) + 49152 = 49792d$
15h	1	5	$(64 * 21) + 49152 = 50496d$

where: L.A. = Logical Address
MSD = Most Significant Digit
LSD = Least Significant Digit

Configuration Switch



This eight-position rocker switch is located near the front center of the board. Its settings determine which VMEbus arbitration level will be used when the module is acting as a Master of the VMEbus (switches 4 and 5), which VMEbus IRQ level its interrupt handler will service (switches 8, 7, and 6), and the type of IEEE-488 addressing to be used (switch 1). The settings of the eight rockers are as follows:

1 - Primary Address:

open = IEEE-488 primary address for each VXI logical address in the mainframe. The two rotary switches on the VX4520 determine the VX4520's VXI logical address and IEEE-488 primary address.

closed = one primary address for the mainframe with secondary address for each VXI logical address in the mainframe. The two rotary switches on the VX4520 determine the IEEE-488 primary address for the entire mainframe.

See the IEEE-488 Interface Device subsection for additional information.

2 - SRQ Generation on Error Detection:

open = IEEE-488 Bus Service Request (SRQ) is generated when the VX4520 detects an error.

closed = SRQ generation on error detection is disabled.

3 - IEEE Address Mapping Algorithm:

closed = the IEEE address is mapped to the logical address using the direct method. This is described in the Operation section.

open = the IEEE address is mapped to the logical address using the shifting method. This is described in Appendix D.

4 and 5 - VMEbus Arbitration Level:

These two switches determine which Bus Request level will be used by the VX4520 when it requests use of the VMEbus. The setting of rockers 4 and 5 for the required Bus Request levels is:

<u>rocker 4</u>	<u>rocker 5</u>	
closed	closed	= level 0
closed	open	= level 1
open	closed	= level 2
open	open	= level 3

6 through 8 - VMEbus Interrupt Handler Level:

These three switches determine which IRQ line on the VMEbus will be monitored by the VX4520. The actions taken by the VX4520 when the selected IRQ line goes true are described in the Operation section of this manual under Interrupt Handler.

If a given instrument in the mainframe uses VMEbus interrupts and is a servant of the VX4520 (for example, instruments 1, 2, 3, or 4 in Figure 2), then the interrupt level chosen for the VX4520 interrupt handler and its servant's interrupt levels must be the same.

NOTE:

The Interrupt Handler may be disabled by setting rockers 6, 7, and 8 to the closed position.

Rocker 8	Rocker 7	Rocker 6	Interrupt Handler set for:
closed	closed	closed	= Interrupt Handler disabled
closed	closed	open	= IRQ1
closed	open	closed	= IRQ2
closed	open	open	= IRQ3
open	closed	closed	= IRQ4
open	closed	open	= IRQ5
open	open	closed	= IRQ6
open	open	open	= IRQ7

Reset Switch

This momentary switch on the front panel is labeled RESET, and is used to perform a system-level reset. Pressing the switch generates the VMEbus' system-reset signal (SYSRESET*) on the VMEbus backplane, and also resets the VX4520 Module's on-board microprocessor. Pressing this switch causes a VXibus hard reset.

ACFAIL Enable

This ON/OFF switch, located near the top front of the circuit board, determines if the ACFAIL* signal from the power supply in the VX1400 Mainframe will be monitored. When the switch is in the OFF position, ACFAIL* is not monitored by the VX4520. If the switch is in the ON position, when ACFAIL* is asserted by the power supply the VX4520 will assert SYSRESET* approximately 2 milliseconds later.

In the VX1400 Mainframe, the ACFAIL* signal is asserted 4 milliseconds before the +5 volt supply falls to +4.875 volts. Thus, by simply monitoring ACFAIL* and SYSRESET*, any module in the system has a 2 millisecond window to perform an orderly shutdown.

EXT CLK 10

The two positions on this front panel toggle switch are labeled EXT and INT. This switch selects the source of the VXibus backplane signal CKL10 as either the on-board internal source or an external source. This feature can be used in multi-cage systems where all cages must have the same CLK10 input.

Fuses

Each of the VX4520 power buses is protected with an on-board fuse to protect other modules within the VXibus chassis in the event that an inappropriate voltage is applied to this module's front panel connector. The fuses also protect the module in case of an accidental shorting of the power busses or any other situation where excessive current might be drawn.

If any of the fuses open, the SYSFAIL* (system failure) line on the VXibus backplane will be asserted.

The VX4520 Module has fuses for +5V and -5.2V.

If either of the fuses opens, remove the fault before replacing the fuse. Figure 1 shows the location of the fuses on the VX4520 Module. Replacement fuse information is given in the Specifications section of this manual.

LEDs

The following LEDs are visible at the top of the VX4520 Module's front panel to indicate the status of the module's operation:

Power LED

When lit, this green LED indicates that the following power supply voltages are present on the backplane: +24, -24, +12, -12, +5, -5.2, and -2. This LED will go out if either the 5V or -5.2V fuse opens, or if any of the other power supply voltages are not present.

SYSFAIL LED

This red LED is lit during the five second self test period following power-up and whenever a module in the mainframe asserts the VMEbus backplane signal SYSFAIL*, including during self test. VX4520 Module failures include failure to correctly complete a self test, loss of a power rail, or failure of the module's central processor. The VX4520 will also light this LED if it detects a failure of a module due to a breakdown of communications, even if the SYSFAIL* signal is unasserted. Reading the status of the VX4520 will extinguish this LED.

ACCESS LED

When lit, this green LED indicates that the VX4520 is either accessing the VMEbus as a master or is currently being accessed as a VMEbus slave. The LED appears to stretch the length of the VMEbus cycle. For example, a 5 microsecond cycle will light the LED for approximately 0.2 seconds. The LED will flash if the module is being constantly addressed or is constantly accessing the VMEbus.

BUSS ACCESS LED

This green LED indicates VMEbus activity by monitoring Address Strobe (AS*) on the VMEbus. It is lit whenever any type of VMEbus cycle is in progress, regardless of which system component is acting as the bus master. As the duty cycle of AS* increases, the LED will become brighter.

LISTEN LED

This green LED is lit whenever a device in the chassis is addressed as a listener on the IEEE-488 bus.

TALK LED

This green LED is lit whenever a device in the chassis is addressed as a talker on the IEEE-488 bus.

SRQ LED

This green LED is lit whenever the SRQ (service request) line on the IEEE-488 bus is set true.

ATTN LED

This green LED is lit whenever the ATN (attention) line on the IEEE-488 bus is set true.

REMOTE LED

This green LED is lit whenever the REN (Remote Enable) line on the IEEE-488 bus is set true.

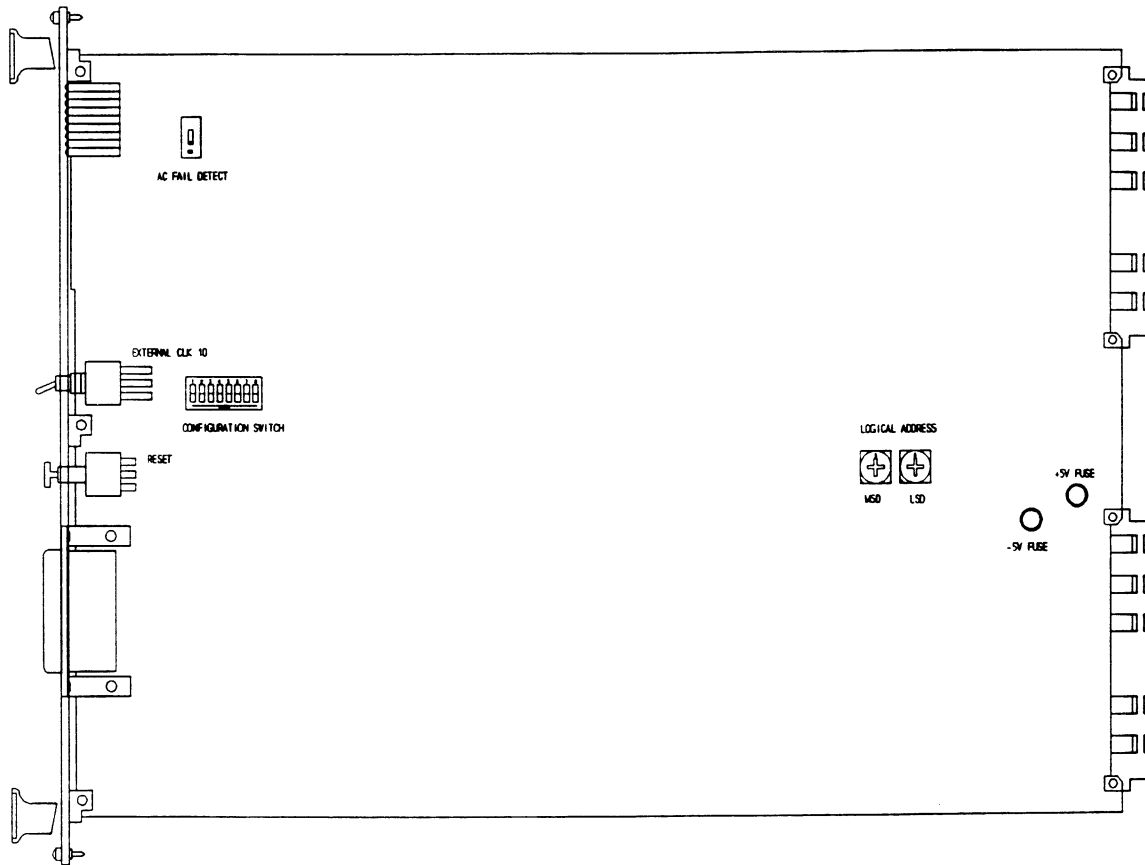

Figure 1: VX4520 Controls and Indicators

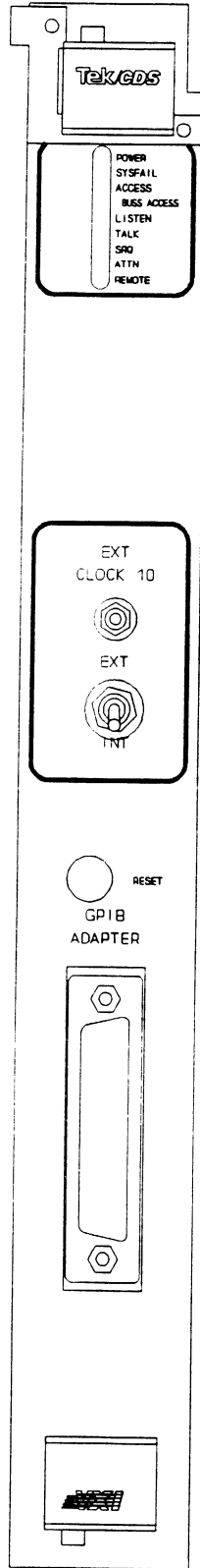

Figure 2: VX4520 Front Panel

Specifications

Functions: VXI Resource Manager, Slot 0 functions, VMEbus controller, and IEEE-488 interface device.

VXI Resource Manager:

Device Type: Message based device.

Devices Supported: V1.0 - 1.3 VXI devices.

Registers: ID.
Device type.
Status.
Response.
Data low.
See Appendix A for definition of register contents.

Logical Address: 0 (may not be altered).

Capability: The Resource Manager is fully compliant with the VXIbus specifications for a Resource Manager.

Slot 0 Function:

CLK10: 10 MHz ECL differential; 10H116 type driver. Internal source or external source, switchable.

External CLK10: Signal level -0.7V to +7V maximum; +0.8V to +2.4V minimum.

MODID Lines: Pulled up by 16.9K ohms; lines may be driven and monitored.

Keying: The left side is keyed for TTL signal levels.

VMEbus Functions:

Bus Master: A24/D16.

Bus Slave: A16/D16.

Bus Arbiter: Prioritized arbiter.

Bus Requestor: Fair requestor.

Arbitration Level: Switch selectable to any level.

System Clock: 16 MHz, 50 ppm, 50%, $\pm 10\%$ duty cycle.

System Reset: Driven by front panel switch.

Interrupt Handler: Single level capability, switchable to any level.

Bus Time Out (BTO):	100 μ s.
Power Monitor:	Both power-up and power-down.
<u>IEEE-488/VXIbus Interface:</u>	
Device Type:	Message based device.
Registers:	ID Device type. Status. Signal. Response. Data low. See Appendix A for definition of register contents.
Logical Address:	1 through 254, switch selectable.
IEEE-488.1 Subsets Supported:	SH1 Source handshake. AH1 Acceptor handshake. TE6 Talker extended. LE4 Listener extended. SR1 Service request. DC1 Device clear. DT1 Device trigger. PPO Parallel poll.
Addressing Capability:	Single primary/multiple secondary or multiple primary. Switch selectable. VX4520 has a unique IEEE-488 address and may be commanded and queried by the System Controller.
IEEE-488 Throughput:	100 μ s start up (GPIB address change).
Listener:	35 KHz per byte, plus any time more than 1.7 μ s required by the servant device for handshaking DTACK* on the VMEbus. This time excludes any System Controller overhead.
Talker:	17 KHz per byte, plus any IEEE-488 System Controller overhead.
<u>General:</u>	
Power Requirements:	All required dc power is provided by the power supply in the VXIbus mainframe.
Voltage:	+ 5 Volt supply: 4.75 V dc to 5.25 V dc.
Current (Peak Module, I_{PM}):	5 Volt supply: 2.5 A.

Section 1

Current (Dynamic Module, I_{DM}):	5 Volt supply: 0.643 A.
Cooling:	Provided by fans in the VXIbus mainframe. The module will have a temperature rise of < 10°C with 1.5 liters/sec of air and a pressure drop of 0.04 mm of H ₂ O.
Temperature:	0°C to +50°C, operating. -40°C to +85°C, storage.
Humidity:	Less than 95% R.H. non-condensing, 0°C to +30°C. Less than 75% R.H. non-condensing, +31°C to +40°C. Less than 45% R.H. non-condensing, +41°C to +50°C.
Radiated Emissions:	Complies with VXIbus Specification.
Conducted Emissions:	Complies with VXIbus Specification.
Module Envelope Dimensions:	VXI X size. 262 mm high, 352 mm deep, 31 mm wide. (10.3 in x 13.9 in x 1.2 in).
Dimensions, Shipping:	When ordered with a VX1400 Mainframe, the module is installed and secured in slot 0 of the mainframe. When ordered alone, shipping dimensions are: 406 mm x 305 mm x 102 mm. (16 in x 12 in x 4 in).
Weight:	1 kg. (2.2 lb).
Weight, Shipping:	When ordered with a VX1400 Mainframe, the module is installed and secured in slot 0 of the mainframe. When ordered alone, shipping weight is: 1.5 kg. (3.2 lb).
Mounting Position:	Any orientation.
Mounting Location:	Installs only in the left-most VXIbus module slot (slot 0) of the mainframe.
Front Panel Signal Connectors:	DB 25S connector, socket. Refer to Appendix B for connector pinouts. SMB connector.

Equipment Supplied: 1 - VX4520 Resource Manager Module.
 1 - Operating Manual (Part # 00000-34520).
 1 - Service Manual (Part # 00000-44520).
 1 - IEEE-488 Cable (Part # 46100-45718) or 1 - IEEE-488 Cable
 (Part # 46100-45716) if ordered as part of a configured
 system.

Software Rev. V4.85

Section 1

Section 2

Preparation For Use

Installation Requirements And Cautions

Since the VX4520 Module performs the VXibus Slot 0 functions, it must be installed in slot 0 of the mainframe being used. In the VX1400 Mainframe, slot 0 is the left-most slot. Be sure the module's switches are correctly set (see the Controls and Indicators and the Operation sections).

Tools Required

The following tools are required for proper installation:

Slotted screwdriver set.



Note that there are two printed ejector handles on the card. To avoid installing the card incorrectly, make sure the ejector marked "VX4520" is at the top.

In order to maintain proper mainframe cooling, unused mainframe slots must be covered with the blank front panels supplied with the mainframe.

Based on the number of instrument modules ordered with a Tektronix/CDS mainframe, blank front panels are supplied to cover all unused slots. Additional VXibus C size single-slot and C size double-slot blank front panels can be ordered from your Tektronix/CDS supplier.



Verify that the mainframe is able to provide adequate cooling and power with this module installed. Refer to the mainframe Operating Manual for instructions.

If the VX4520 is used in a VX1400 Mainframe, all VX4520 cooling requirements will be met.

Installation Procedure



The VX4520 Module is a piece of electronic equipment and therefore has some susceptibility to electro-static damage (ESD). ESD precautions must be taken whenever the module is handled.

- 1) Record the Revision Level, Serial Number (located on the PCB of the VX4520), and switch settings on the Installation Checklist. Only qualified personnel should perform this operation.
- 2) Verify that the switches are set to the desired values.
- 3) Make sure power is off in the mainframe.
- 4) The module can now be inserted into slot 0 of the mainframe.

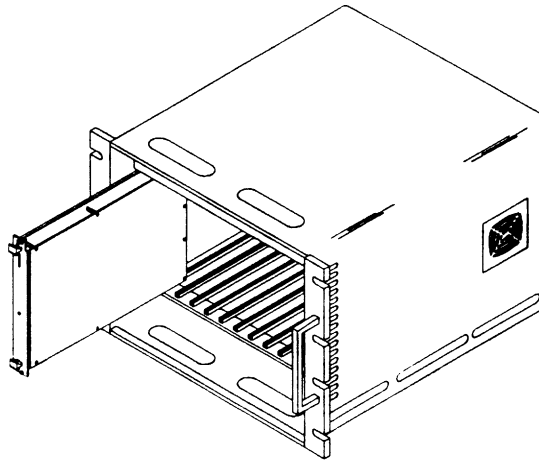

Figure 2: Module Installation

- 5) Cable Installation -

Install the Interface Cable in the cable tray of the VX1400 Mainframe. The far end of the cable has an IEEE-488 connector and is placed in the cable tray and extended out the rear of the mainframe. The end of the cable extending from the front of the cable tray is terminated with a hooded connector that is plugged into the DB25 connector marked "P4" on the front panel of the VX4520 Module.

The mainframe is interfaced to the system controller using a standard IEEE-488 cable to connect the IEEE-488 connector on the end of the cable to the IEEE-488 interface connector at the system controller.

Installation Checklist

Installation parameters will vary depending on the mainframe being used. Be sure to consult the mainframe Operating Manual before installing and operating the VX4520 Module.

Revision Level: _____

Serial No.: _____

Mainframe Slot Number: 0 (can not be changed)

Switch Settings:

VXibus Logical Address Switch: _____

Configuration Switch:

Rocker 1: open closed

Rocker 4: open closed

Rocker 5: open closed

Rocker 6: open closed

Rocker 7: open closed

Rocker 8: open closed

ACFAIL Enable: on off

External CLK10: EXT INT

Cable Installed: _____

Performed by: _____ Date: _____

Section 2

Section 3

Operation

Overview

The VX4520 Module is a C size single slot VXIbus Message Based Word Serial instrument for use in slot 0 of a VXIbus system. The VX4520 contains a Dynamic Configuration Resource Manager, slot 0 functions, IEEE-488 interface device, and VMEbus system controller functions defined by the VXIbus Specification, Version 1.3.

The VX4520 has two sets of registers that conform to the VXIbus Specification for Message Based Devices. One set of message based registers is for the Resource Manager, at logical address 0. The other set of registers, for the IEEE-488 Interface device, has a selectable logical address that is set using the two rotary switches described in the Switches subsection of this manual.

The VX4520 now offers new features in full support for VXIbus Version 1.3 devices. An expanded set of commands allows more complete control of test systems. These commands are extensions to VXIbus requirements and are in addition to normal IEEE-488 operation (the default mode). They provide the more experienced user with important additional capabilities, including the ability -

- ▶ to reconfigure the default Commander/Servant hierarchy;
- ▶ to dynamically reconfigure the interrupt matrix;
- ▶ to move a device from one VXIbus-defined matrix to another; and
- ▶ to use timeouts to control the length of time the VX4520 polls for Read and/or Write Ready bits during Word Serial Protocol communication.

Information about the system and the devices in the system is easy to obtain under program control. In addition to operating parameters, you can determine: device logical address, device commander's logical address, manufacturer ID, model code, slot number, slot 0 logical address, device class, memory space, memory offset, memory size, pass/ fail, manufacturer specific comments (if any), device IEEE address, VXIbus support information, and VXIbus Operational State.

Power-up

Following power-up or system reset, the VX4520 will perform a self test of on-board memory. The self test will last a maximum of five seconds. The Resource Manager will then initialize the VXI system. If any failure occurs during self test, the red Sysfail LED will remain lit after the five second self test period, and an error message will be sent to the system controller the next time the VX4520 is specifically addressed as a talker on the IEEE-488 bus.

Module Operation

Resource Manager

The Dynamic Configuration Resource Manager is a VXI Message Based device at logical address 0. After a five second delay following power-up or system reset, the Resource Manager begins to initialize the system and build a configuration table containing system information. The information from the table may be passed through the IEEE-488 interface to the system controller using the TABLE command described in the VXI User Interface Command section of this manual.

The Resource Manager performs the following functions after power-up or system reset:

1. Identify all VXIbus devices in the system:
After a delay of five seconds, the Resource Manager attempts to read the ID register at each of the other 255 VXIbus logical addresses. If no bus error occurs at an address, then a device is present at that logical address and is added to the configuration table.
2. Acquire module information:
The Resource Manager determines slot location (using the MODID lines), Manufacturer ID, and Model Code for each device in the mainframe and adds this information to the configuration table.
3. Perform Sysfail Test:
If SYSFAIL is asserted, the Resource Manager attempts to determine the device(s) asserting SYSFAIL. Each device found to be asserting SYSFAIL is placed in the Soft Reset State with SYSFAIL assertion inhibited.
4. Configure the system's Commander/ Servant hierarchies:
The Resource Manager establishes a system wide Commander/Servant control hierarchy as described in the VXIbus Specification. This step includes sending the GRANT DEVICE command to any commander in the mainframe that responded to the READ SERVANT AREA query with a non-zero value. See Figure 2 for an example of a typical system hierarchy.

5. Dynamic configuration:

Perform dynamic configuration of any VXI device that has its logical address set to 255. Dynamic configuration can only occur if no Static configuration VXI device has its logical address set to 255.

6. Configure the system's A24 and A32 address maps:

The Resource Manager reads the address space requirements of each A24 and A32 device that was added to the configuration table. If an A24 or A32 device is present and requires additional address space, then an offset is calculated so that no two devices' address spaces overlap. This value is written to the device's Offset register.



Non-VXIbus devices (with the exception of an Adapter Module) are undetectable, since they do not contain VXIbus configuration registers, and may cause address space overlap problems.

7. VME IRQ line allocation:

VME Interrupt Request lines are first allocated to programmable interrupt handler devices. Then, any remaining lines are allocated to programmable interrupter devices. The rules for IRQ line allocation are defined in the VXIbus Specification version 1.3, section C.4.1.5.

8. Identify commander:

The Resource Manager sends the Identify Commander command to all instruments in the mainframe which are servants of the VX4520 and which have VMEbus master capability. This allows devices to use VXIbus signaling rather than interrupts for sending events and responses to the VX4520.

9. Initiate normal operation:

The Resource Manager sends the Begin Normal Operation command to all the Message Based Devices the VX4520 controls, in order of increasing logical address.

10. Determine RSTB and Lock command support:

The Resource Managers sends the Clear Lock and RSTB word Serial Protocol commands to each message based device it controls. If the receiving device does not generate an Unrecognized Command error, the device is assumed to support the commands. This information is added to the Resource Manager's device configuration array.

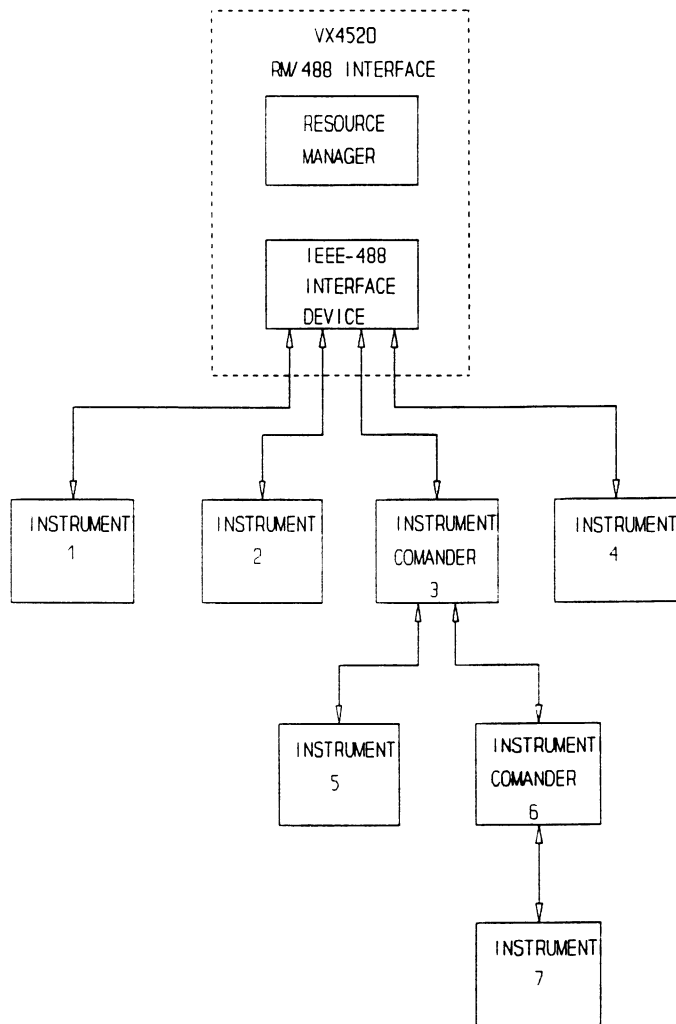

Figure 3: Typical System Hierarchy

Slot 0 Functions

The slot 0 device is neither a register nor Message Based device. The slot 0 functions required by the VXibus are supplied by the VX4520 Module and are hidden within the Resource Manager. The slot 0 functions include CLK10 (a 10 MHz differential ECL clock driver for the backplane) and transceivers for the MODID lines.

IEEE-488 Interface Device

The IEEE-488 Interface Device is a VXibus Message Based commander that converts IEEE-488 protocol to VXibus instrument protocol. It routes the incoming IEEE-488 data to the proper instrument in the mainframe and returns instrument responses to the IEEE-488 controller. The IEEE-488 device does not examine or parse any 488 data unless it is specifically addressed to the VX4520.

The Configuration switch setting determines whether the direct or shifting method will be used. The shifting method is described in Appendix D.

DIRECT METHOD

IEEE-488 Multiple Primary Address Mapping

When position 1 of the Configuration switch is set open, IEEE-488 addresses are translated to VXIbus logical addresses as follows:

- ▶ The VXIbus logical address of the VX4520 IEEE-488 Interface Device is determined by the setting of the two hexadecimal rotary switches on the VX4520 Module.
- ▶ Logical addresses of VXIbus devices, including the VX4520, from 1 to 30, correlate directly to an IEEE-488 primary address. If the logical address is 31 or greater, the VX4520 will assign IEEE-488 addresses in ascending order, filling in unallocated addresses in the address list. For example:

Module Logical Address	IEEE-488 Primary Address
1	1
47	2
3	3
4	4
128	5
7	7
20	20

With a logical address greater than 30, adding another card to the mainframe or moving the module to another slot may change the module's IEEE-488 address. This will require changes to the user's application program.

It is recommended that the logical address chosen for each module be the same as the slot number, so that the module's IEEE-488 address will be the same number as its logical address.

IEEE-488 Single Primary/Multiple Secondary Address Mapping

When configuration switch position 1 is set closed, IEEE-488 addresses are translated to VXIbus logical addresses as follows:

- ▶ The IEEE-488 primary address for the mainframe is determined by the setting of the two hexadecimal rotary switches on the VX4520 Module.
- ▶ The IEEE-488 interface device is automatically assigned secondary address 30. Any other module given logical address 30 will be reassigned.

- ▶ Logical addresses from 1 to 29 correlate directly to an IEEE-488 secondary address. Logical addresses greater than 29 will be assigned secondary addresses in ascending order, filling in unallocated addresses in the address list. For example:

Module Logical Address	IEEE-488 Secondary Address
1	1
47	2
3	3
4	4
128	5
7	7
20	20

VMEbus System Functions

As the VMEbus controller, the VX4520 Module provides the VMEbus-arbiter, system-clock driver, bus-timer, system-reset driver, interrupt-daisy-chain driver, and interrupt handler functions:

1. **Bus Arbiter:**
The bus arbiter arbitrates bus requests and grants the bus on four levels, 0 through 3. Level 3 has the highest priority and level 0 has the lowest priority. If the level of the current bus master is lower than the level of the current bus request, the bus arbiter initiates a bus clear. The VXIbus Specification requires that the "Fair Requestor" scheme be implemented by modules in the system.
2. **System-clock Driver:**
The system-clock driver generates a 16-MHz 50% (nominal) duty-cycle signal. This clock has no fixed phase relationships with other VMEbus timing.
3. **Bus Timer:**
The bus timer monitors all VMEbus data transfers and asserts the VMEbus signal BERR* if a transfer takes longer than 100 μ s. The timer is started on the negative transition of either Data strobe (DS1 or DS0) and reset on the positive transition of either Data strobe.
4. **Power-up Reset:**
When power is applied to the VX1400 Mainframe, the VX4520 Module provides a VMEbus system reset for a minimum of 200 ms as defined in the VMEbus Specification.
5. **IACK (Interrupt Acknowledge) Daisy-chain Driver:**
This circuitry complies with the VMEbus Specification for generating a falling edge on the IACK daisy-chain driver each time any interrupt handler initiates an IACK cycle.

6. Interrupt Handler:

The VX4520 Module contains an Interrupt Handler that is enabled when positions 6 through 8 of the module's Configuration switch are set for an IRQ level between 1 and 7, as described in the Configuration Switch subsection. The Interrupt Handler will execute when the VMEbus IRQ line that matches the Configuration switch setting is active. The Interrupt Handler performs the following functions:

- a) It performs a VMEbus D16 interrupt acknowledge cycle to obtain the STATUS/ID of the interrupting device. The interrupting device will return a 16-bit code, where the lower eight bits contain the ID (logical address) and the upper eight bits contain the STATUS (cause for interrupt).
- b) If the ID (logical address) is for a VXibus Message Based Device, then step c) is performed. Otherwise, the interrupt handler terminates operation.
- c) If the Status is a Response (bit 15 set to 0), then the configuration table is updated with that device's status. If the Status is an Event (bit 15 set to 1), then the event is handled as defined in the IEEE-488 Interface Device section of the VXibus Specification.

IEEE-488 Control Lines

The VX4520 Module's implementation of individual IEEE-488 bus control lines is as follows:

EOI (End Or Identify)

The VX4520 will set EOI on the IEEE-488 bus true when it receives data from a card that was addressed to talk and bit 8 of the 16 bit data transfer is set to a 1.

SRQ (Service Request)

The SRQ line on the IEEE-488 bus will be set true when the VX4520 receives the Request True event from a servant which it controls. It is set false when it receives the Request False event from that same servant only if no other servant has sent the Request True event. It will also be set false when a serial poll occurs for the instrument which sent the Request True event to the VX4520 and no other instrument has sent a Request True event to the VX4520.

The VX4520 also generates the SRQ signal on error occurrence, if enabled to do so. The VX4520 can be enabled to generate SRQs on errors in two ways:

- a) with the SRQ command.
- b) with the VX4520 Configuration switch, which can set the initial mode of SRQ generation following power-up. If the Configuration switch rocker #2 is open, SRQs will be generated whenever an error is detected. If the rocker #2 is closed, SRQs are not generated on errors. This initial setting for the generation of SRQs can be modified during operation with the SRQ command.

IFC (Interface Clear)

When the bus controller asserts the IEEE-488 bus IFC line, the IEEE-488 interface on the VX4520 Module goes into a quiescent state and is unaddressed as an active talker or listener. The IFC line is intended to clear the IEEE-488 interface, and therefore servants of the VX4520 are not affected by the IFC line going active.

DAV (Data Valid)

Implemented per IEEE-488 Standard, 1978.

NRFD (Not Ready For Data)

Implemented per IEEE-488 Standard, 1978.

NDAC (Not Data Accepted)

Implemented per IEEE-488 Standard, 1978.

REN (Remote Enable)

Implemented per IEEE-488 Standard, 1978.

ATN (Attention)

Implemented per IEEE-488 Standard, 1978.

IEEE-488 Bus Commands

The IEEE-488 Specification refers to multiline messages which can be used to obtain predefined uniform actions from bus instruments. Multiline messages are commonly referred to as "universal" commands and "addressed" commands. These commands can only be sent to individual bus instruments by the bus controller (station computer) when the ATN (attention) line on the bus is true. The VX4520 response to these messages is as follows:

Universal Commands

Device Clear (DCL)

When the DCL command is received, the IEEE-488 interface device sends the VXibus CLEAR command to all VXibus instruments which are its direct servants. The CLEAR command is sent using the Word Serial protocol.

Serial Poll Enable (SPE)

Polling is a method the IEEE-488 bus controller uses to determine which instrument on the bus has requested service (generated an SRQ). When the SPE command is received, the VX4520 enters the Serial Poll Active State (SPAS). If secondary addressing is being used, the system controller must be capable of a serial poll using secondary addresses.

Once the serial poll begins, the VX4520 may respond in one of two ways, depending on the capabilities of the VXibus module requesting service:

1. IF the IEEE-488 controller places a Talk address on the bus,
AND that Talk address is for an instrument in the mainframe,

AND that instrument is IEEE-488.2 compatible OR responds to the READ STB command,
THEN the VX4520 will send the VXIbus READ STATUS BYTE command to that instrument.

The VX4520 then reads the status byte of that instrument (using the Word Serial Protocol) and returns it to the IEEE-488 controller.

2. IF the IEEE-488 controller places a Talk address on the bus,
AND that Talk address is for an instrument in the mainframe
AND that instrument is not IEEE-488.2 compatible
AND does not respond to the READ STB command,
THEN IF that instrument is the one that sent the Request True event to the 151,
THEN the VX4520 will return a hexadecimal 40 to the IEEE-488 controller (bit 6 set), or
ELSE an ASCII null (hex 0) is returned to the controller.

Serial Poll Disable (SPD)

When the SPD command is received, the VX4520 will exit the IEEE-488 SPAS state and return to the IEEE-488 idle state. If a serial poll did occur for the instrument which sent the Request True event to the VX4520 and no other instrument has sent a Request True event to the VX4520, then the SRQ line on the bus is set false.

Addressed Commands

Group Execute Trigger (GET)

When the GET command is received, the IEEE-488 interface device sends the VXIbus TRIGGER command to all VXIbus instruments which are addressed to listen and have trigger capability indicated by the Trigger bit in their VXIbus Protocol register. The TRIGGER command is sent using the Word Serial protocol.

Selected Device Clear (SDC)

When the SDC command is received, the IEEE-488 interface device sends the VXIbus CLEAR command to all VXIbus instruments which are addressed to listen. The CLEAR command is sent using the Word Serial protocol.

Service Request (SRQ) Operation

The SRQ line on the IEEE-488 bus is set by bus instruments whenever they require service from the system controller. If the SRQ is set true, the system controller will perform a serial poll to determine the cause of the SRQ. The VX4520 will set the IEEE-488 bus SRQ line true, if enabled to do so by either the Configuration switch (rocker position 2) or the software command SRQ, when it detects a VXIbus Request True event from any of its servant modules in the mainframe. The Request True event may be sent to the VX4520 with VMEbus interrupts or with VXIbus signaling.

The conditions under which modules generate Request True events are described in the Operating Manual for the individual modules. The VX4520 will set the SRQ line false when a serial poll occurs for the instrument which sent the Request True event to the VX4520 and no other instrument has sent a Request True event to the VX4520.

System Operation

Sysfail Operation

If a SYSFAIL occurs, the VX4520 will send a Sysfail Inhibit to each VXIbus device in turn. When SYSFAIL goes inactive, the VX4520 identifies the device that last received Sysfail Inhibit as the source of the SYSFAIL. Once determined, the failed device is placed in the Soft Reset state with Sysfail assertion inhibited, as defined by the VXIbus Specification.

Power-up Sysfail Management:

At power-up, if Sysfail is detected the VX4520 handles the situation as described above. That is, it tries to determine which device is asserting SYSFAIL, then tries to inhibit it, and generates appropriate error messages.

Runtime Sysfail Management:

Runtime Sysfail management is more complex. If no V1.3 commanders are present in the system, then Sysfail processing occurs as in a V1.2 system (as described above). If V1.3 commanders are present, the resource manager waits two seconds to allow the commanders to perform their required Sysfail processing. If Sysfail is still asserted after two seconds, the VX4520 assumes the device asserting Sysfail is not a servant of a V1.3 commander and attempts to remove Sysfail, as described in the Power-up Sysfail management paragraph above.

Alternative Sysfail Management:

An alternative Sysfail interrupt handler can be installed that only inhibits the generation of the Sysfail signal and does not place the device into the 'Safe State'. This Sysfail management is useful during device development, debug or whenever the user does not want a failed device placed into the 'Safe State'. The alternative Sysfail handler can be installed by issuing the following command to the VX4520: "SetHdl 0 11 1". The alternative Sysfail handler remains in effect until the system is reset. (It is possible to reset the system and maintain the alternative Sysfail handler. See the description of the Reset command.)

DCL and SDC

The VX4520 responds to the IEEE-488 commands DEVICE CLEAR (DCL) and SELECTED DEVICE CLEAR (SDC) by sending VXI CLEAR commands to the appropriate devices.

Trigger Support

The VX4520 does not drive the VXI trigger lines.

Command Summary

The VX4520 has its own unique IEEE-448 address, as described in the Switches subsection. When the VX4520 is addressed as a Listener on the IEEE-488 bus, it will recognize certain ASCII strings that will cause an action to occur or cause a response to be formatted and returned to the IEEE-488 controller the next time the VX4520 is addressed as a Talker on the bus.

A summary of the VX4520 Module's commands is listed below in alphabetical order. This is followed by detailed descriptions of each of the commands.

Command Action

BNO	issues the Begin Normal Operation command to the indicated device.
BUSTIME	modifies the IEEE-488 bus settling time.
BUSTIME?	returns the current GPIB bus settling time.
DLAD?	returns a list of the logical addresses for all devices in the VXI system.
DLIS?	returns information on the devices comprising the VXI system.
DNUM?	returns the number of devices in the VXI system.
ENO	issues the End Normal Operation Word Serial Protocol (WSP) command to the indicated device.
GRANT	the servant device at a specified logical address will be granted to the commander device at a specified logical address.
HDLLINE	returns the VME interrupt request line (IRQ) associated with a specified interrupt handler at a specified logical address.
HDLMATRIX	returns the interrupt handler matrix maintained internally by the Resource Manager.
HELP	returns help information on the user interface commands the Resource Manager interprets.
INTLINE	returns the VME interrupt request line (IRQ) associated with the specified Interrupter at a specified logical address.
INTMATRIX	returns the interrupter matrix table maintained internally by the Resource Manager.
LOCK	sends the Word Serial Protocol commands SET LOCK or CLEAR LOCK to the indicated VXIbus device.
MAP	specifies a particular IEEE-488 address to be associated with a particular logical address.
READHDLS	returns the number of interrupt lines the device at a specified logical address may handle simultaneously, i.e. the number of interrupt handlers on that device.

READINTS	returns the number of interrupt lines the device at a specified logical address may drive simultaneously, i.e. the number of interrupters on that device.
RED	reads VME memory space.
RELEASE	specifies that the servant device at a specified logical address be released from the commander device at a specified logical address.
RESET	resets a selected VXI device.
SETHDL	updates the Interrupt Handler Matrix table in the Resource Manager.
SETINT	allows the Interrupter Matrix table in the Resource Manager to be modified and optionally causes the interrupt hierarchy to be modified to match the matrix.
SRQ	enables or disables the generation of IEEE-488 SRQs whenever the VX4520 detects an error.
STATUS	returns the current error status of a VXI device.
TABLE	directs the VX4520 to return the number of devices and configuration information for each device in the mainframe which it controls.
TEST	causes the VX4520 to execute its built-in self test routine.
TIMEOUT	assigns the amount of time the VX4520 waits for the assertion of the Read Ready and/or Write Ready bits in a device's Response register during Word Serial Protocol data transfers.
WRT	writes to VME memory space.
WSCMD	sends a specified Word Serial Protocol command (not requiring a response) to a VXI device.
WSCMD?	sends a specified Word Serial Protocol command (requiring a response) to a VXI device. The response value is returned in ASCII decimal format.

Command Description Syntax

The syntax and symbols used in the command descriptions are:

- () optional parameter
 - { } group of parameters
 - ... optional repetition
- (The (), {}, and ... characters are not part of the command.)

<CR> represents the carriage return character, decimal 13. Its use is host-specific and it may not be required as a terminator. Consult the host's Operating Manual.

<LF> represents the line feed character, decimal 10. Its use is host-specific and it may not be required as a terminator. Consult the host's Operating Manual.

white space

used to separate fields in a command containing multiple parameters. Valid white space characters are blank and comma.

LA the Logical Address parameter, represents the logical address (1 - 255) of the VXIbus device, expressed in either ASCII decimal or ASCII hexadecimal notation. If an ASCII hex number is used, it must be preceded by '#H' or '#h'.

underlines

Data returned by the VX4520 to the system controller through the IEEE-488 bus is underlined in the examples that follow each command.

VXI User Interface Commands

Command: BNO (Begin Normal Operation)

Syntax: BNO LA <CR> <LF>

Purpose: This command issues the BEGIN NORMAL OPERATION Word Serial Protocol command to the device at logical address LA.

Description: LA represents the logical address (1 - 255) of the VXIbus device to receive the command, expressed in either ASCII decimal or ASCII hexadecimal notation. If an ASCII hex number is used, it must be preceded by '#H' or '#h'.

In most simple systems, this command would not be required. The VX4520 sends a Begin Normal Operation Word Serial Protocol command to each of its direct message based servants following the power-up sequence. The BNO command would typically be used to restart operation if an End Normal Operation command had been sent to a module to allow reconfiguration of commander/servant or interrupt hierarchies.

Example: BNO 14 <CR> <LF>

This sends the BNO command to the VXIbus device with a logical address of decimal 14.

Errors: If the selected device does not exist or is not a message based servant of the VX4520, an Invalid Logical Address error is generated.

If the device's Status register indicates that it has not passed (or completed) the self test then a Device Has Not Passed Self Test error is generated.

If the device has its Sysfail Inhibit bit set, then a Device Has Sysfail Inhibited error is generated.

If the device has its Reset bit set, then a Device Is In Reset State error is generated.

Command: BUSTIME (Assign IEEE-488 Bus Settling Time)

Syntax: Bustime (488BusTime) <CR> <LF>

Purpose: This command modifies the IEEE-488 bus settling time. The bus settling time is the minimum amount of time the 488 interface hardware will wait for the bus to settle between individual GPIB access cycles. The power-up default GPIB bus settling time is 600 ns.

Description: The optional parameter 488BusTime has two values, Slow and Medium. These values are entered as ASCII strings. The value Slow corresponds to a bus settling time of 2.2 μ s. Medium corresponds to 1.2 μ s. If omitted, the parameter defaults to a bus settling time of 600 ns.

The IEEE-488 bus settling time will be initialized to Fast (600ns) when the Resource Manager is hard reset. With soft resets, the user has the option of maintaining a previously assigned bus settling time. See the RESET command description.

Example: Bustime slow <CR> <LF>

This example would assign a 2.2 μ s IEEE-488 bus settling time.

Errors: Any parameter other than Slow or Medium will generate an Invalid Command error.

Command: BUSTIME? (IEEE-488 bus settling time Query)

Syntax: Bustime? <CR> <LF>

Purpose: This command returns the current GPIB bus settling time.

Description: This current IEEE-488 bus settling time is returned as one of three ASCII strings. Slow is returned when the bus settling time is 2.2 μ s. Medium is returned when the settling time is 1.2 μ s. Fast is returned for a 600 ns settling time.

Example: Bustime? <CR> <LF>

Slow <CR> <LF>

This example shows the ASCII string 'Slow' being returned, indicating the current IEEE-488 bus settling time is 2.2 μ s.

Command: DLAD?

Syntax: DLAD? <CR> <LF>

Purpose: This command returns a list of the logical addresses for all devices in the VXI system.

Description: The command returns comma separated ASCII decimal integers whose values will range from 0 to 255 inclusive. The last decimal integer is followed by the <CR> <LF> characters.

Example: If the system has five VXIbus devices, then the command

DLAD? <CR> <LF>

returns a list of the five devices' decimal logical addresses, for example:

000,001,016,064,254 <CR> <LF>

Command:	DLIS?
Syntax:	DLIS? (LA) <CR> <LF>
Purpose:	This command returns information on a device(s) comprising the VXI system.
Description:	LA represents the logical address (1 - 255) of the VXIbus device to receive the command, expressed in either ASCII decimal or ASCII hexadecimal notation. If an ASCII hex number is used, it must be preceded by '#H' or '#h'.

If the optional parameter, LA, is omitted, then information on all devices in the system is returned. If the logical address parameter is specified, then only information pertaining to the referenced device is returned. The individual fields of a particular device are comma separated. Fields of different devices are semi-colon separated. The returned data fields are defined as follows:

device logical address:

ASCII decimal integer from 0 to 255 inclusive.

device commander's logical address:

ASCII decimal integer from -1 to 255 inclusive. -1 indicates this device has no commander.

VXIbus manufacturer ID:

ASCII decimal integer from 0 to 4095 inclusive.

model code:

The manufacturer's defined model code, an ASCII decimal integer from 0 to 65535 inclusive.

slot number:

The device's slot number: an ASCII decimal integer from -1 to the number of slots that exist in the cage. -1 indicates the slot for this device is not known.

slot 0 logical address:

ASCII decimal integer from -1 to 255 inclusive. -1 indicates the slot 0 device for this module is not known.

device class:

Three ASCII characters, defined as one of the following strings:
(MEM), (EXT), (MSG), or (REG)
which represent the four device classes: Memory, Extended, Message Based, and Register Based, as defined by the VXIbus Specification.

memory space:

Three ASCII CHARACTERS, defined as one of the following strings:
(A16), (A24), (A32), or (RES)

which represent the addressing modes of the device. RES is reserved for future VXIbus definition.

memory offset:

The base address of the A24 or A32 address of a device. This value will be expressed as an eight digit ASCII hex number using the IEEE-488.2 Specification '#H' format, and zero padded if necessary. A zero is placed in this field if the device does not support A24/A32 addressing.

memory size:

The size of A24 or A32 address space used by the device. This value will be expressed as an eight digit ASCII hex number using the '#H' format, and zero padded if necessary. A zero is placed in this field if the device does not support A24/A32 addressing.

pass/fail:

Four ASCII characters, defined as one of the following strings: (PASS), (FAIL), or (EXT).

Note that 'EXT' is preceded by a space character.

extended field 1:

This field is up to 80 characters long and is reserved for future VXIbus use.

extended field 2:

This field is up to 80 characters long and is reserved for future VXIbus use.

extended field 3:

This field is up to 80 characters long and is reserved for future VXIbus use.

manufacturer-specific comment:

This field is up to 80 characters long and is defined by the resource manager manufacturer. For the VX4520, this field may contain any of the following comma separated, device dependent data:

device IEEE-488 address:

Two digit ASCII decimal integer, 01 to 30 inclusive.

TRIGGER:

ASCII characters "TRIGGER", if the device has trigger capability.

LOCK:

ASCII characters "LOCK", if the device supports the Word Serial Protocol Lock commands.

RSTB:

ASCII characters "RSTB", if the device supports the Word Serial Protocol Read STB command.

FOREIGN:

ASCII characters "FOREIGN" if the VX4520 detects the presence of a non-VXIbus device.

V1.3 ASCII characters "V1.3" if the device is V1.3 compatible.

Operational State:

ASCII characters "NORMAL" if the device is in the Normal Operation state. ASCII characters "CONFIGURE" if the device is in the Configure state.

NOTE: Foreign devices may contain blanks in some of the previously described fields.

Examples: DLIS? 0 <CR> <LF>

This command requests information about the VXIbus device at logical address 0. The following is a typical example of returned information:

000,-1,4093,04520,00,000,MSG,A16,0,0,PASS,,,,01,Ver4.2 <CR> <LF>

<u>Field</u>	<u>Contains</u>	<u>Represents</u>
1	000	the device's logical address.
2	-1	indicates the device has no commander, i.e. it is the Resource Manager.
3	4093	the device manufacturer's VXIbus ID Code.
4	04520	the device's model code.
5	00	the slot number of the device.
6	000	the logical address of the Slot 0 device for this module.
7	MSG	the VXI device class. In this case, the device is a Message Based Device.
8	A16	indicates the type of memory the device can access. In this example the device is an A16 device, which can access 1 megabyte of VME memory.
9	0	the base address of A24 or A32 address space allocated by the Resource Manager to this device. Since this is an example of an A16 device, this field is zero.

10 0 the size of the A24 or A32 memory required by this device. Since this is an example of an A16 device, this field is zero.

11 PASS indicates the device passed its built in self test.

The next three fields are null fields, reserved for future VXIbus uses. The null fields are indicated by comma separators.

15 01 the IEEE-488 address of this device.

16 Ver4.2 the version of software being used. This field will only be shown for DLIS? 0.

Because this is the last field in the response, it is terminated with a <CR> <LF>.

Example 2: DLIS? <CR> <LF>

This command, without the optional LA parameter, requests information about all VXI devices in this mainframe. If the system contained two VXIbus devices, the logical address 0 device described in Example 1 and a second device, then the returned information might be as follows:

000,-1,4093,04520,00,000,MSG,A16,0,0,PASS,,,,01;
127,000,4092,00535,04,000,MSG,A24,#H00200000,#H00010000,PASS,,,,04,RSTB,
V1.3,NORMAL<CR><LF>

The first line of returned data is identical to the previously described example except that the version number does not appear, and the line terminates in a semi-colon. This character indicates that there is at least one more line of device information still to be read. The second line of device information is interpreted as follows:

<u>Field</u>	<u>Contains</u>	<u>Represents</u>
1	127	the device's logical address.
2	000	the logical address of the device's commander; in this case, the system's Resource Manager.
3	4092	the device manufacturer's VXI ID Code.
4	00535	the device's model code.
5	04	the slot number of the device.
6	000	the logical address of the Slot 0 device for this module.

- 7 MSG the VXI device class. In this case, the device is a Message Based Device.
- 8 A24 indicates the type of memory the device can access. In this example the device is an A24 device, which can access 16 megabytes of VME memory.
- 9 #H00200000 the base address of A24 or A32 address space allocated by the Resource Manager to this device. This device has been allocated A24 address space beginning at A24 memory location 0 (200000 hex).
- 10 #H00010000 the size of the A24 or A32 memory required by this device. This device requires 65536 bytes of A24 memory.
- 11 PASS indicates the device passed its built in self test.

The next three fields are null fields, reserved for future VXIbus uses. The null fields are indicated by comma separators.

- 15 04,RSTB,V1.3,NORMAL <CR> <LF>
the manufacturer's comment field. Based on the capabilities of this device, the VX4520 returns the following device-specific values in this field:
1. the device's IEEE-488 address.
 2. an indication that the device supports the Read STB Word Serial Protocol command.
 3. V1.3 if the device is V1.3 compatible.
 4. the operational status of the device.

Because this is the last field in the response, it is terminated with a <CR> <LF>.

Command: DNUM?

Syntax: DNUM? <CR> <LF>

Purpose: This command returns the number of devices in the VXI system.

Description: The returned value is a single ASCII decimal integer ranging from 1 to 256 inclusive, terminated with <CR> <LF> characters.

Example: DNUM? <CR> <LF>
010 <CR> <LF>

The DNUM? command returns the ASCII decimal number '010', indicating that there are ten VXIbus devices in the mainframe, in this example.

Command: ENO (End Normal Operation)

Syntax: ENO LA <CR> <LF>

Purpose: This command issues the End Normal Operation Word Serial Protocol command to the device referenced by LA.

Description: LA represents the logical address (1 - 255) of the VXIbus device to receive the command, expressed in either ASCII decimal or ASCII hexadecimal notation. If an ASCII hex number is used, it must be preceded by '#H' or '#h'.

This command is typically used to put an instrument in the Configure mode to permit system level activities such as reconfiguring interrupt levels and commander/servant relationships.

Example: ENO #h0A <CR> <LF>

This example issues the Word Serial END NORMAL OPERATION command to logical device #h0A.

Errors: If the selected device does not exist or is not a message based servant of the VX4520, an Invalid Logical Address error is generated.

- Command:** GRANT (Grant a Servant)
- Syntax:** GRANT CommanderLA ServantLA <CR> <LF>
- Purpose:** The Grant command specifies that the servant device at logical address ServantLA be granted to the commander device at logical address CommanderLA.
- Description:** The Grant command allows the user to reassign servants to commanders while in the VXIbus Configure mode. On power-up, servants are usually automatically granted to commanders based on the servant area the commander specifies it has, and consecutive logical addresses of servants. This command permits user reconfiguration.
- CommanderLA is the logical address of the commander to be granted the servant. ServantLA is the logical address of the servant granted to the commander. Both logical addresses may be expressed in either ASCII decimal or ASCII hexadecimal notation. If an ASCII hex number is used, it must be preceded by '#H' or '#h'.
- Example:** GRANT 5 6 <CR> <LF>
- This command would grant the device at logical address 6 as servant to the device at logical address 5.
- Errors:** An Invalid Logical Address error is generated if no device is present at either of the specified logical addresses.
- A Device Is Not a Commander error is generated if the specified commander device does not have commander capability.
- A Servant Belongs To Another Commander error is generated if the specified servant device belongs to another commander.
- NOTE:** An Exceeding Servant Area Size warning message is generated if you try to grant more devices than specified by the commander's servant area size; however, the GRANT command is still issued.

Command: HDLLINE (Read Handler Line)

Syntax: HDLLINE LA Handler <CR> <LF>

Purpose: The HDLLINE command returns the VME interrupt request line (IRQ) associated with the specified interrupt Handler on device LA.

Description: LA the logical address (1 - 255) of the VXIbus device to receive the command, expressed in either ASCII decimal or ASCII hexadecimal notation. If an ASCII hex number is used, it must be preceded by '#H' or '#h'.

Handler a single digit number from 1 to 7 which specifies the interrupt handler number. On a typical device with one interrupt handler, Handler would be equal to 1.

This command is used in conjunction with the Read Number of Handlers and Modify Interrupt Handler Matrix commands to modify or interrogate the interrupt handler hierarchy of a VXIbus system.

This command is usually preceded by a Read Number of Handlers command which returns the number of interrupt handlers on the device. If the device has two handlers, HDLLINE LA 1 and HDLLINE LA 2 commands could then be sent to determine which IRQ lines each handler is assigned to.

If the returned value is 0, the specified interrupt handler is disconnected from all IRQ lines.

Example: HDLLINE 6 2 <CR> <LF>
1 <CR> <LF>

This command sends the Read Handler Line Word Serial Protocol command to a device at logical address 6 (that is known to have at least two interrupt handlers) requesting which IRQ line the second handler is assigned to. The returned value of 1 indicates that interrupt handler 2 is connected to VMEbus interrupt line 1.

Errors: If the selected device does not exist or is not a message based device, an Invalid Logical Address error is generated.

If the device does not support programmable interrupt handlers a Device Does Not Support Programmable Interrupt handlers error is generated.

If the handler value is less than 1 or larger than the number of handlers on the device, an Invalid Interrupt Handler error generated.

Command: HDLMATRIX (List Interrupt Handler Matrix)

Syntax: HDLMATRIX <CR> <LF>

Purpose: The HDLMATRIX command returns the interrupt handler matrix maintained internally by the Resource Manager.

Description: This command is used in conjunction with the List Interrupter Matrix command to determine the state of the interrupt structure in a VXIbus system.

This command will only report interrupt handlers that support the VXIbus Programmable Handler capability. For a complete description of the interrupt handler structure, any interrupt handlers configured with manual switch settings must also be included.

Example: HDLMATRIX <CR> <LF>

Response:

<u>INT HANDLER LA</u>	<u>INT HANDLER #</u>	<u>IRQ</u>
<u>033</u>	<u>2</u>	<u>6</u>
<u>024</u>	<u>1</u>	<u>1</u>

where: LA is the logical address of the interrupt handler device.
HANDLER # is the interrupt handler number.
IRQ is the VME IRQ line associated with this interrupt handler.

Command: HELP

Syntax: HELP (Cmd) <CR> <LF>

Purpose: This command returns help information on the user interface commands the Resource Manager interprets.

Description: Cmd can be any command supported by the Resource Manager

When the command is entered by itself, without a parameter, a list of all user interface commands supported by the Resource Manager is returned. Seven commands are listed per line, with no command parameters or description. If the optional parameter 'Cmd' is used, the formal definition of the specified command with its various parameters and their definitions is returned.

Example: The command

HELP WRT <CR> <LF>

would return all of the following information:

WRT ADrChg ADrMod VMEAdr; Data <CR> <LF>

This command allows 16 bit data writes to the VME bus.

AdrChg - increment, decrement or don't change VME address after each write. Allowable values: I or i, D or d, or N or n.

AdrMod - VME address modifier. If ASCII hex is used, precede number with "#H"

VMEAdr - physical VME address. If ASCII hex is used, precede number with "#H"

Data - the actual data to be written. If ASCII hex is used, precede number with "#H"

- Command:** INTLINE (Read Interrupter Line)
- Syntax:** INTLINE LA Interrupter<CR> <LF>
- Purpose:** The INTLINE command returns the VME interrupt request line (IRQ) associated with the specified Interrupter on device LA.
- Description:** LA the logical address (1 - 255) of the VXibus device to receive the command, expressed in either ASCII decimal or ASCII hexadecimal notation. If an ASCII hex number is used, it must be preceded by '#H' or '#h'.

Interrupter a single digit number from 1 to 7 which specifies the interrupt number. On a typical device with one interrupter, this value would be equal to 1.

This command is used in conjunction with the Read Number of Interrupters and Modify Interrupter Matrix commands to modify or interrogate the interrupt hierarchy of a VXibus system. This command is usually preceded by a Read Number of Interrupters command, which returns the number of interrupters on the device. If the device has two interrupters, an INTLINE LA 1 and INTLINE LA 2 could then be sent to determine which IRQ lines each interrupter is assigned to.

If the returned value is 0, the specified interrupter is disconnected from all IRQ lines.
- Example:** INTLINE 6 2 <CR> <LF>
1 <CR> <LF>
- This command sends the Read Interrupter Line command to a device at logical address 6 (known to have at least two interrupters) requesting which IRQ line the second interrupter is connected to. The returned value of 1 indicates that interrupter 2 is connected to VMEbus interrupt line 1.
- Errors:** If the selected device does not exist or is not a message based device, an Invalid Logical Address error is generated.

If the interrupter value is less than 1 or larger than the number of interrupters on the device, an Invalid Interrupter error generated.

If the device does not support programmable interrupts a Device Does Not Support Programmable Interrupts error is generated.

Section 3

Command: INTMATRIX (List Interrupt Matrix)

Syntax: INTMATRIX <CR> <LF>

Purpose: The INTMATRIX command returns the interrupter matrix table maintained internally by the Resource Manager.

Description: This command is used in conjunction with the List Handler Matrix command to determine the state of the interrupter structure in a VXIbus system.

This command will only report interrupters that support the VXIbus Programmable Interrupters capability. For a complete description of the interrupter structure, any interrupters configured with manual switch settings must also be included.

Example: INTMATRIX <CR> <LF>

Response:

<u>INT HANDLER LA</u>	<u>INT HANDLER #</u>	<u>IRQ</u>
<u>033</u>	<u>2</u>	<u>6</u>
<u>024</u>	<u>1</u>	<u>1</u>

where: LA is the logical address of the interrupt handler device.
HANDLER # is the interrupt handler number.
IRQ is the VME IRQ line associated with this interrupt handler.

Command: LOCK

Syntax: LOCK LA (Clear) <CR> <LF>

Purpose: This command sends the Word Serial Protocol commands Set Lock or Clear Lock to the VXI device defined by the logical address LA.

Description: LA the logical address (1 - 255) of the VXIbus device to receive the command, expressed in either ASCII decimal or ASCII hexadecimal notation. If an ASCII hex number is used, it must be preceded by '#H' or '#h'.

If the optional parameter 'clear' is not specified, the Set Lock command is sent. If the optional parameter 'clear' is specified, the Clear Lock is sent.

The Set Lock and Clear Lock commands set and clear the Locked bit on a message based VXIbus device. A set Locked bit indicates that access from local services is locked out.

Historically, in IEEE-488 systems the IEEE-488 interface used this capability to lock out control from a manual front panel on an instrument that was controlled both remotely via the IEEE-488 interface and locally with front panel manual controls.

Examples: Example 1: LOCK 23 <CR> <LF>

This command sends the Set Lock command to the VXIbus device with the logical address of decimal 23.

Example 2: LOCK #H14 CLEAR <CR> <LF>

This command sends the Clear Lock command to the VXIbus device with logical address 14 hex (20 decimal).

Errors: The specified device must be a servant of the VX4520 Module and support the Word Serial Protocol Lock command. If not, an Invalid Logical Address error will be generated.

Command: MAP

Syntax: MAP LA IEEEAdr<CR> <LF>

Purpose: This command associates a particular IEEE-488 address with a particular Logical Address (LA).

Description: LA the logical address (1 - 255) of the VXIbus device to receive the command, expressed in either ASCII decimal or ASCII hexadecimal notation. If an ASCII hex number is used, it must be preceded by '#H' or '#h'.

IEEEAdr the IEEE-488 address to be mapped to the logical address. It must not be currently in use.

At power-up the VX4520 Resource Manager assigns IEEE-488 addresses to VXIbus device logical addresses using the algorithm described in the IEEE-488 Interface Device subsection of this manual. This command permits the user to change an IEEE-488 address for compatibility with previously written software, etc.

The MAP command is valid in either the Configure or Normal VXIbus operation mode.

Use the TABLE command to determine the current logical address/IEEE-488 address mapping matrix before making any changes, and to verify the results of the MAP command.

Example: MAP 145 9<CR> <LF>

With this command, the VXIbus device at decimal logical address 145 is set to the IEEE-488 bus address of 9.

Errors: If the logical address is less than 1 or greater than 255, an Invalid Logical Address Error is generated.

If a VXI device does not exist at the specified address, or a VXI device exists there that is not a servant of the VX4520 address (i.e. a servant of another Commander in the VXI mainframe), then an Invalid Logical Address error is generated.

If the IEEE-488 address is less than 1 or greater than 30 or if the IEEE-488 address is already assigned, then an Invalid IEEE-488 Address error is generated.

Command: READHDLS (Read Number of Handlers)

Syntax: READHDLS LA <CR> <LF>

Purpose: This command returns the number of interrupt lines the device at LA may handle simultaneously, i.e. the number of interrupt handlers on that device.

Description: LA the logical address (1 - 255) of the VXIbus device to receive the command, expressed in either ASCII decimal or ASCII hexadecimal notation. If an ASCII hex number is used, it must be preceded by '#H' or '#h'.

This command causes the Word Serial Protocol Read Handlers command to be sent to the message based device at logical address LA. The response will be an ASCII decimal number between 0 and 7. If the response is 0, the device has no programmable interrupt handlers.

The command is used in conjunction with the Read Handler Line and Modify Interrupt Handler Matrix commands to modify the interrupt handler structure of a VXIbus system.

Example: READHDLS 6 <CR> <LF>
7 <CR> <LF>

This command sends the Read Handlers Word Serial Protocol command to the device at logical address 6. The returned value of 7 indicates that the device has the capacity to handle interrupts on all seven VMEbus interrupt lines.

Errors: If the selected device does not exist or is not a message based device, an Invalid Logical Address error is generated.

If the device does not support programmable interrupt handlers a Device Does Not Support Programmable Interrupt Handlers error is generated.

Command: READINTS (Read Number of Interrupters)

Syntax: READINTS LA <CR> <LF>

Purpose: The READINTS command returns the number of interrupt lines the device at LA may drive simultaneously, i.e. the number of interrupters on that device.

Description: LA the logical address (1 - 255) of the VXIbus device to receive the command, expressed in either ASCII decimal or ASCII hexadecimal notation. If an ASCII hex number is used, it must be preceded by '#H' or '#h'.

The command causes a Word Serial Protocol Read Interrupters command to be sent to the selected LA. The response will be an ASCII decimal number between 0 and 7. If the response is 0, the device has no programmable interrupters.

The command is used in conjunction with the Read Interrupter Line and Modify Interrupter Matrix commands to modify the interrupter structure of a VXIbus system.

Example: READINTS 6 <CR> <LF>
7 <CR> <LF>

The example sends the Read Interrupters Word Serial Protocol command to the device at logical address 6. The returned value of 7 indicates that the device has the capacity to generate interrupts on all seven VMEbus interrupt lines.

Errors: If the selected device does not exist or is not a message based device, an Invalid Logical Address error is generated.

If the device does not support programmable interrupts a Device Does Not Support Programmable Interrupts error is generated.

Command: RED (Read)

Syntax: RED z₁ z₂ z₃ z₄ z₆ <CR> <LF>

Purpose: This command reads VME memory space.

Description: The Read command requires five parameters, separated by valid white space characters. After the VX4520 receives this ASCII command string, it is then addressed as a talker on the IEEE-488 bus. The IEEE-488 system controller may then begin inputting the results of the VMEbus reads. If the selected VMEbus address does not contain a device that returns DTACK, a VMEbus error is generated.

The command parameters are defined as follows:

- z₁ This parameter specifies whether the VME address for successive reads will be incremented, decremented, or remain the same. There are three allowable values for this field:
- I (or i) - for incrementing the VME address
 - D (or d) - for decrementing the VME address
 - N (or n) - for a constant address

All VME address reads are 16 bit reads, and address incrementing and decrementing modify the VME address reference by ± 2 . Any z₁ values other than the three specified above will cause an Invalid Command error to be generated.

- z₂ This parameter specifies the VME address modifier to be used for the read cycle. The field may contain any two digit number in ASCII from 0 to 63 (3F hex). If an ASCII hex number is used, it must be preceded by '#H' or '#h'. Typical address modifiers are #H29 for A16 address space and #H39 for A24 address space.
- z₃ This parameter specifies the physical VME address to be used in the read cycle. The field may contain from one to six ASCII digits. ASCII hex numbers must be preceded by '#H' or '#h'. The address value is rounded down to an even value, if necessary.
- z₄ This parameter specifies whether the data returned to the system controller will be in ASCII decimal or ASCII hex format. VMEbus data returned as ASCII decimal is formatted as five decimal digits, padded with leading zeros; ASCII hex data is formatted as four hex digits, with leading zero padding. The allowable values for this field are:
- H (or h) - for ASCII hex format
 - D (or d) - for ASCII decimal format
- z₆ This parameter specifies the number of VMEbus reads that are to take place. This field must contain a number in ASCII from 1 to 50 (32 hex). ASCII hex numbers must be preceded by '#H' or '#h'. Commas separate

the individual VMEbus read data values. A <CR> <LF> character sequence will be sent to the system controller at the end of the read sequence.

Example: RED i #h29 #hCOC0 H 4 <CR> <LF>

xxxx,xxxx,xxxx,xxxx<CR> <LF>

This command performs four VMEbus 16-bit data reads. The address modifier field specifies A16 address space. The VMEbus initial address of COC0 hex is incremented between successive reads. The return data is formatted as ASCII hex. After sending this command to the VX4520, the next time the VX4520 is addressed as a IEEE-488 talker the string shown above will be returned to the system controller, where xxxx represents the actual VMEbus data, shown as four ASCII hexadecimal digits.

Command: **RELEASE** (Release a Servant)

Syntax: **RELEASE CommanderLA ServantLA <CR> <LF>**

Purpose: The Release command specifies that the servant device at logical address ServantLA be released from the commander device at logical address CommanderLA.

Description: The Release command allows the user to release servants from their assigned commanders while in the VXIbus Configure mode. On power-up, servants are usually automatically granted to commanders based on the servant area the commander specifies it has, and consecutive logical addresses of servants. This command permits user reconfiguration.

CommanderLA the logical address of the commander which has been granted the servant.

ServantLA the logical address of the servant to be released from the commander.

Both logical addresses may be expressed in either ASCII decimal or ASCII hexadecimal notation. If an ASCII hex number is used, it must be preceded by '#H' or '#h'.

This command is used in conjunction with the GRANT command for restructuring the hierarchy of the VXIbus system.

Example: **RELEASE 11 12<CR> <LF>**

This example will release the servant at logical address 12 from the commander at logical address 11.

Errors: An Invalid Logical Address error is generated if no device is present at either of the specified logical addresses or if either logical address specifies the VX4520 itself.

A Device Is Not a Commander error is generated if the specified commander device does not have commander capability.

A Servant Does Not Belong To This Commander error is generated if the specified servant device does not currently belong to the specified commander.

Command:	RESET
Syntax:	RESET (LA)('SAFE') <CR> <LF>
Purpose:	This command resets either the entire VXI chassis or a selected VXI device.
Description:	LA the logical address (0 - 255) of the VXIbus device to receive the command, expressed in either ASCII decimal or ASCII hexadecimal notation. If an ASCII hex number is used, it must be preceded by '#H' or '#h'.

The LA parameter is optional. If specified, the referenced device is reset as described. If omitted, the entire VXI mainframe (each device in the cage) is reset and the system is re-initialized as though a hard reset had occurred. The only difference is that the VXIbus signal SYSRESET is not asserted.

If an LA parameter is specified, and the device referenced is not the VX4520, and the optional 'Safe' parameter is not used, then the Reset Bit of the device's Control register remains set for at least 100 μ sec (but less than 300 μ secs), and then clears to '0'. After a device has been reset, the VX4520 waits for five seconds before attempting any additional IEEE-488 bus activity.

If the optional 'Safe' parameter is specified, both the Reset bit and Sysfail Inhibit bit of the device's Control register are set true, and the device is placed in the 'Safe' state.

If the LA parameter references the VX4520 (LA = 0 or LA = the logical address of the VX4520 IEEE device), each device in the mainframe is reset, including the VX4520, but the 'Safe' parameter is not allowed. This is a special case of the Reset command, in which some system control values are not re-initialized:

- * **Interrupt Matrix Table.** This table contains the current system interrupt matrix, which lists which interrupters and interrupt handlers on which devices are allocated to which VME IRQ lines (see Interrupt Control commands). Issuing the Reset command and specifying the VX4520's logical address allows you to reset and re-initialize the system without losing the current interrupt matrix information. The non-zero interrupt matrix table is detected by the VX4520's Resource Manager during system initialization, and each programmable interrupter and interrupt handler device is automatically programmed with the matrix table values. Consequently, the various interrupt matrix setup commands need not be re-issued.

- * **Ready Timeout Value.** This value specifies the amount of time the VX4520 will wait for the assertion of the Read Ready and/or Write Ready bits during Word Serial Protocol. The power-up default value is five seconds. This value can be modified with the Timeout command. Then issuing the Reset command and specifying the VX4520's logical address resets and re-initializes the system using

the modified Timeout value. This provides a convenient way to accommodate devices with unusually slow initialization sequences.

- * **SYSFAIL Interrupt Handler.** Assertion of the VXI signal SYSFAIL generates an interrupt to the VX4520's Resource Manager. It is the responsibility of the resulting Sysfail interrupt handler to process the Sysfail signal. The power-up default handler detects the device that is asserting Sysfail and places it in the 'Safe State' by setting the Sysfail Inhibit and Reset bits of the failed device's Control register, (as specified by the VXI Specification). A device in 'Safe State' cannot process Word Serial Commands and has very limited capabilities. This situation is not always desired, particularly during device development and debug. An alternative, more benign, Sysfail interrupt handler may be installed. See the section of the manual describing Sysfail management. Issuing the Reset command and specifying the VX4520's logical address allows you to reset and re-initialize the system without reinstalling the default Sysfail interrupt handler.

If a VXI device does not exist at the selected logical address, an Invalid Logical Address error is generated.

Resetting the Resource Manager (that is, issuing the Reset command with the logical address parameter equal to 0) resets all the VXI devices in the chassis, including the VX4520 IEEE device as well as the Resource Manager itself. In effect, this is a system wide soft reset.

Resetting the VX4520 IEEE device (that is, issuing the Reset command with the logical address parameter equal to logical address of the VX4520 IEEE device) resets all the VXI devices in the chassis, including the VX4520 IEEE device, but not the Resource Manager. This means that any VME interrupt matrix that has been established is not lost, and re-initialization of the system will automatically re-allocate the VME interrupt request lines as defined by this matrix.

When a VXI device (other than the VX4520) is reset, it is placed into the Configure substate operational mode. Before that device can again process Normal substate mode Word Serial Commands, the Begin Normal Operation command must be sent to the device.

Examples: Example 1: RESET 23 <CR> <LF>

This command toggles the Reset bit of the Control register of the device at logical address 23.

Example 2: RESET 6 SAFE <CR> <LF>

This command sets the Reset bit and the Sysfail Inhibit bit in the Control register of the device at logical address 6. The device is placed in the 'Safe' state.

Command:	SETHDL	(Modify Interrupt Handler Matrix)
Syntax:	SETHDL LA Handler IRQ ('Send') <CR> <LF>	
Purpose:	The SETHDL command updates the Interrupt Handler Matrix table in the Resource Manager. It associates the Interrupt LA, Interrupt Handler Number and the VME IRQ line in the matrix table.	
Description:	LA	the logical address (1 - 255) of the VXIbus device to receive the command, expressed in either ASCII decimal or ASCII hexadecimal notation. If an ASCII hex number is used, it must be preceded by '#H' or '#h'.
	Handler	a single digit number from 1 to 7 which specifies the interrupt handler number. On a typical device with one interrupt handler, Handler would be equal to 1.
	IRQ	the VME IRQ line in the matrix table. An IRQ value equal to 0 indicates the interrupt handler is to be disconnected from the specified IRQ line, and the table values for that IRQ line are cleared out.
	'Send'	an optional parameter. If the 'Send' parameter is included, then Word Serial Protocol Assign Handler Line command is issued to assign the specified interrupter to the specified IRQ line.

This command is used in conjunction with the Read Number of Handlers and Read Handler Line commands to modify a VXIbus system's interrupt handler hierarchy.

The VMEbus specification only permits one interrupt handler per IRQ line. Assigning two different devices to handle the same IRQ will cause improper operation, sometimes subtle and hard to find problems, in a VMEbus system. Handler numbers can be assigned to devices at power-up, or by switch settings on non-VXIbus devices or VXIbus devices without programmable Handler capabilities.

This command should not be used without complete knowledge of the interrupt structure of a system, including knowledge of any manual switch settable interrupt handlers not reported by the List Interrupt Handler Matrix command. It may only be sent when the device is in the VXIbus Configure sub-mode.

This command is often required in situations where a VXIbus line with programmable handler is handling interrupts from a device without programmable interrupt capability. The resource manager has no knowledge of the IRQ line the interrupter is using and will probably not assign a handler to the correct line on power-up. This command permits the user to assign the handler to the desired IRQ line compatible with a switch setting on the interrupter.

An alternative Sysfail interrupt handler can be installed that only inhibits the generation of the Sysfail signal and does not place the device into the 'Safe State'. This Sysfail management is useful during device development, debug or whenever the user does not want a failed device placed into the 'Safe State'. The alternative Sysfail handler can be installed by issuing the following command to the VX4520: "SetHdl 0 11 1". The alternative Sysfail handler remains in effect until the system is reset. (It is possible to reset the system and maintain the alternative Sysfail handler. See the description of the Reset command.)

Example: `SETHDL 6 2 3 <CR> <LF>`

This example will connect the device at logical address 6's second interrupt handler to VMEbus interrupt line 3.

Errors: If the selected device does not exist or is not a message based device, an Invalid Logical Address error is generated.

If the device does not support programmable interrupt handlers a Device Does Not Support Programmable Interrupt Handlers error is generated.

If the handler value is less than 1 or larger than the number of handlers on the device, an Invalid Handler error generated.

If the IRQ value is less than 0 or greater than 7, then an Invalid IRQ error is generated.

If the device is in the normal operation substate, an Invalid Device Substate error is generated.

Command: SETINT (Modify Interrupter Matrix)

Syntax: SETINT LA Interrupter IRQ ('Send') <CR> <LF>

Purpose: The SETINT command updates the Interrupter Matrix table in the Resource Manager. It associates the device at LA, the Interrupter Number on the device and the VME IRQ line in the matrix table. It can also cause the interrupt hierarchy to be modified to match the matrix.

Description: LA the logical address (1 - 255) of the VXIbus device to receive the command, expressed in either ASCII decimal or ASCII hexadecimal notation. If an ASCII hex number is used, it must be preceded by '#H' or '#h'.

Interrupter the interrupter number on the device at the specified logical address.

IRQ the VME IRQ line in the matrix table.

'Send' an optional parameter. If the 'Send' parameter is included, then Word Serial Protocol Assign Interrupter Line command is issued to assign the specified interrupter to the specified IRQ line.

An IRQ value equal to 0 indicates the interrupter is to be disconnected from the specified IRQ line, and the table values for that IRQ line are cleared out.

This command is often required in situations where a VXIbus device is being used with a device with a switch set interrupt handler. The resource manager has no knowledge of the IRQ line the handler is using and will probably not assign the interrupter to the same line on power-up. This command permits the user to assign the interrupter to the IRQ line compatible with a switch setting on the interrupt handler. It may only be sent when the device is in the VXIbus Configure sub-mode.

Example: SETINT 6 2 3 <CR> <LF>

This command will connect the device at logical address 6's second interrupt to VMEbus interrupt line 3.

Errors: If the IRQ value is less than 0 or greater than 7, then an Invalid IRQ error is generated.

If the interrupter value is less than 1 or larger than the number of interrupters on the device, an Invalid Interrupter error is generated.

If the selected device does not exist or is not a message based device, an Invalid Logical Address error is generated.

If the device does not support programmable interrupts, a Device Does Not Support Programmable Interrupts error is generated.

If the device is in the normal operation substate, an Invalid Device Substate error is generated.

Command: SRQ (Service Request Enable/Disable)

Syntax: SRQ ('Clear') <CR> <LF>

Purpose: This command enables or disables the generation of IEEE-488 SRQs whenever the VX4520 detects any operational error.

Description: The SRQ command by itself enables the generation of SRQ signals. The optional ASCII parameter 'Clear' disables the generation of SRQ signals. The command has no effect on SRQ generation as caused by the VXI Request True or Request False event.

Examples: Example 1: SRQ <CR> <LF>

This command enables the generation of SRQ signals when errors occur.

Example 2: SRQ CLEAR <CR> <LF>

This command disables the generation of SRQ signals on error occurrence.

Command: STATUS

Syntax: STATUS (LA) <CR> <LF>

Purpose: This command returns the current error status of a VXI device.

Description: LA the logical address (1 - 255) of the VXIbus device to receive the command, expressed in either ASCII decimal or ASCII hexadecimal notation. If an ASCII hex number is used, it must be preceded by '#H' or '#h'.

If the optional LA parameter is omitted, then the current error status of the VX4520 Module is returned. If the optional parameter is specified and matches the logical address of the Resource Manager or the IEEE-488 VX4520 device, then the current error status of the VX4520 Module is returned. Error status information returned by the VX4520 is formatted as ASCII character strings. If there is no current error to report, a null string is returned.

A logical address parameter referencing any other VXI device will cause the Resource Manager to try to obtain the current error status of that device by issuing the Word Serial Protocol Read Protocol Error command.

Error status values returned by the device are displayed in ASCII hex format. If the device buffers its errors, multiple error query commands can be issued until the device's Response Register error bit indicates that there are no more errors to report. Multiple error status values are formatted as comma separated ASCII hex values. If the device has no error to report, a null string is returned. Error status types supported are: multiple queries error, unsupported command, DIR and DOR violation, and Read Ready and Write Ready violation.

Examples: Example 1: STATUS <CR> <LF>
 <CR> <LF>

This command requests the current status of the VX4520. If there are no errors, the response is the null string <CR> <LF>.

Example 2: STATUS #h20 <CR> <LF>
 FFFCH <CR> <LF>

This command requests the current status of the VXIbus device at logical address 20 hex (32 decimal). The example of a returned response indicates an Unsupported Command.

Errors: If the referenced device is not a Message Based Device, or is not a servant of the VX4520, an Invalid Logical Address error is generated.

If the device does not support the Read Protocol Error command, then a Device Does Not Support WSP Read Protocol Error command is generated.

Command: TABLE

Syntax: TABLE<CR> <LF>

Purpose: This command directs the VX4520 to return information on each logical device in the VXIbus mainframe.

Description: First, the number of devices in the mainframe is returned as a two digit ASCII decimal number with a <CR> <LF> appended. The VX4520 then goes into the Table Active mode. While in this mode, each time the VX4520 is addressed as a talker on the IEEE-488 bus it will return an ASCII string of information about one of the logical devices in the mainframe.

The VX4520 will leave the Table Active mode if:

- 1) the VX4520 has returned an ASCII string for each device in the mainframe which it controls, or
- 2) the VX4520 is addressed as a listener on the IEEE-488 bus and receives a new command.

NOTE: The VX4520 will remain in the Table Active mode even if some other device in the mainframe is addressed as an active talker/listener on the IEEE-488 bus.

The ASCII string for each device will return a maximum of ten fields, with each field separated by a comma, and the ASCII string terminated with a <CR> <LF>. The following fields will be sent for each device:

Field 1: "LA xx" - Where xx is the logical address of the device in ASCII decimal.

Field 2: "IEEE xx" - Where xx is the IEEE-488 address of the device in ASCII decimal.

Field 3: "SLOT xx" - Where xx is the slot number of the device in ASCII decimal. This field is blank for devices that have not implemented the VXIbus MODID bit in the Status register.

Field 4: "MFG xxxh" - Where xxx is the Manufacturer ID of the device's VXIbus ID register. xxx is returned as ASCII hex.

Field 5a: "MODEL VXxxxx" - This ASCII string is returned for Field 5 if Field 4 was for a Tektronix/CDS device (manufacturer's ID - FFDh). xxxx is returned as ASCII decimal.

Field 5b: "MODEL 73A-xxx" - This ASCII string is returned for Field 5 if Field 4 was for a Tektronix/CDS device (manufacturer's ID - FFCh). xxx is returned as ASCII decimal.

- Field 5c: "MODEL xxxhx" - This ASCII string is returned for Field 5 if Field 4 was not a Tektronix/CDS device. xxxhx is returned as ASCII hex.
- Field 6a: "PASS" - This ASCII string is returned for Field 6 if the device's Passed bit in its VXIbus Status register is set TRUE and its Extended bit is set TRUE (1).
- Field 6b: "FAIL" - This ASCII string is returned for Field 6 if the device's Passed bit in its VXIbus Status register is set FALSE.
- Field 6c: "EXT" - This ASCII string is returned for Field 6 if the device's Passed bit in its VXIbus Status register is set TRUE and its Extended bit is set FALSE (0).
- Field 7a: "488.2" - This ASCII string is returned for Field 7 if the device is a 488.2 instrument.
- Field 7b: "[a];[b];[c]" - This ASCII string is returned for Field 7 if the device is not a 488.2 instrument but does support certain commands in a 488.2 manner. Valid strings for this field are "TRIGGER", "READ STB" and "LOCK". Any combination of these strings may appear in Field 7 depending on what the device supports. If a device does not support any 488.2 commands then the field will be an ASCII space.
- Field 8: "[device type]" - This field specifies the device type. Valid strings for this field are: "MESG", "REG", "MEM", "EXT", "FOREIGN", and "CMDR", corresponding to Message Based Device (non-Commander), Register Based Device, Memory Device, Extended Device, non-VXIbus Device, and Message Based Device (Commander).
- Field 9: "[hierarchy]" - This field contains the logical address of the device's commander. The hierarchy information is returned as a two digit ASCII hex number.
- Field 10: "V1.3" - This field is present only if the device is compatible with VXI Specification 1.3. The field is absent otherwise.
- Field 11: "[operational mode]" - This field specifies whether a Message Based Device that is a servant of the VX4520 has been issued the Begin Normal Operation command. Valid strings for this field are "NORMAL" and "CONFIGURE". "NORMAL" will be returned if the device successfully executed the BEGIN NORMAL OPERATION command.

Example: TABLE<CR> <LF>

If the VXIbus mainframe contained two devices, a VX4520 Module in Slot 0 and a CDS 73A-353 Module in slot 1, the following response would be returned:

LA 0, IEEE 01, SLOT 0, MFG FFDh, MODEL VX4520, PASS, ,RM<CR> <LF>
LA 1, IEEE 01, SLOT 0, MFG FFDh, MODEL VX4520, PASS, ,CMDR<CR> <LF>
LA 2, IEEE 02, SLOT 1, MFG FFCh, MODEL 73A-353, PASS, TRIGGER; LOCK,
MESG, 1, V1.3, NORMAL<CR> <LF>

Two logical address responses are returned for the VX4520 since it contains both a VXIbus to IEEE-488 interface device (LA 1) and a VXIbus Resource Manager (LA 0). Not all devices will contain values in all fields.

Command: TEST

Syntax: TEST <CR> <LF>

Purpose: This command directs the VX4520 Module to execute its built-in self test routine.

Description: The test executed by this command is the same self test routine that is executed at power-up. The results of the self test can be obtained by sending the STATUS command to the VX4520. If an error occurred during the self test, an error message is returned. If no errors occurred, a null string is returned. The Sysfail LED on the VX4520 is turned on during execution of the self test routine. If the VX4520 passes its self test, the Sysfail LED is turned off. If the self test fails, the Sysfail LED remains on.

Example: TEST <CR> <LF>

An error message response might be:

7: 4520 Failed Self Test

Command: TIMEOUT (TimeoutValue)

Syntax: TIMEOUT (z) <CR> <LF>

Purpose: This command specifies the amount of time the VX4520 waits for the assertion of the Read Ready and/or Write Ready bits in a device's Response register during Word Serial Protocol data transfers.

Description: z the timeout value, specified in tens of milliseconds.

The timeout value must be an integer in the range $0 \leq \text{timeout} \leq 65535$ decimal. The value may be specified in ASCII decimal or ASCII Hex.

The timeout parameter is optional. If omitted, the default value of 5 seconds is assigned. The power-up default time is five seconds.

When the RESET 0 command is executed, the default value of five seconds is assigned. When RESET LA is executed and LA references the VX4520 IEEE device, the timeout value remains what it was prior to the Reset command. That is, resetting the VX4520 IEEE device does not modify the current assignment of the timeout value.

Examples: TIMEOUT 100 <CR> <LF> assigns the timeout value to be 1 second.

Timeout <CR> <LF> assigns the default value of 5 seconds.

Command: WRT (Write)

Syntax: WRT z₁ z₂ z₃;Data <CR> <LF>

Purpose: This command writes to VME memory space.

Description: The WRT command requires three parameters, as well as the data to be written to the selected VME address space. If the selected VMEbus address does not contain a device that returns DTACK, a VMEbus Error is generated. The command parameters are separated by a space character. Multiple data bytes are separated by a space character. The z parameters and data are separated by a semicolon (;). The command is terminated with <CR> <LF>. The z parameters are defined as follows:

- z₁ This parameter specifies whether the VME address for successive writes will be incremented, decremented, or remain the same. There are three valid values for this field:
- I (or i) - for incrementing the VME address
 - D (or d) - for decrementing the VME address
 - N (or n) - for a constant address

All VME address writes are 16-bit writes, and address incrementing and decrementing modify the VME address reference by ± 2 . Any z₁ values other than the three specified above will cause an Invalid Command error to be generated.

- z₂ This parameter specifies the VME address modifier to be used for the write cycle. The field may contain any 2-digit ASCII number from 0 to 63 (3F hex). If an ASCII hex number is used, it must be preceded by '#H' or '#h'.

- z₃ This parameter specifies the physical VME address to be used in the write cycle. The field may contain from one to six ASCII digits. ASCII hex numbers must be preceded by '#H' or '#h'. The address value is rounded down to an even address, if necessary. z₃ is immediately followed by a semicolon (;).

Data

This parameter contains the actual data to be written to VME address space and must consist of a 16-bit value. This field may contain any ASCII numeric value. ASCII Hex values must be preceded by '#H' or '#h'. The VX4520 will translate the ASCII number to a binary number prior to transmitting the value over the bus. <CR> <LF> characters at the end of the data field will terminate the write sequence, and do not get transmitted across the VMEbus.

Examples: Example 1: WRT n #h29 #hCOCE;#hBC43 #hBC30 #hBD35 <CR> <LF>

This command would cause three 16-bit VMEbus writes to occur at VME address COCE hex using VME address modifier 29 hex (A16 space). The VME address would not change between consecutive writes. The three data values written would be BC43 hex, BC30 hex, and BD35 hex.

Example 2: WRT i 57 #hFFC408; #h3031 #h3839 #h4142 <CR> <LF>

This command would cause three 16-bit VMEbus writes to occur at VME address FFC408 hex using VME address modifier 57 (39 hex, A24 space). The VME address would be incremented by 2 between successive writes. The first data value (3031 hex) would be written to FFC408 hex; the next (3839 hex) would be written to FFC40A hex; the last (4142 hex) would be written to FFC40C hex.

NOTE: The VX4520 Module cannot address A32 memory.

Command: WSCMD (Word Serial Protocol Command)

Syntax: WSCMD LA CMD<CR> <LF>

Purpose: This command is used to send Word Serial Protocol commands that do not generate a response by the receiving device. The command sends the Word Serial Protocol command specified by 'CMD' to the VXI device specified by the Logical Address parameter (LA).

Description: LA the logical address (1 - 255) of the VXIbus device to receive the command, expressed in either ASCII decimal or ASCII hexadecimal notation. If an ASCII hex number is used, it must be preceded by '#H' or '#h'.

CMD the Word Serial Protocol command (as defined by the VXIbus Specification) to be sent to the logical device at address LA. The command and data can be expressed in either ASCII decimal or ASCII hex notation. If an ASCII hex number is used, it must be preceded by '#H' or '#h'.

If the referenced logical device does not exist, or is not a Message Based Device, or references the VX4520 IEEE device, an Invalid Logical Address error is generated. If the eight most significant bits of the command value do not correspond to a valid Word Serial command, an Invalid Command error is generated.

The effects of the command are not reflected in the Resource Manager's Configuration Array. Do not use this command to send Word Serial commands that generate responses by the receiving VXI device. Use the WSCMD? command for that purpose.

NOTE: Some Word Serial Protocol commands that did not require a response in Revision 1.2 of the VXIbus Specification do require a response in Revision 1.3. This requires special attention when using WSCMD and WSCMD? commands. The Begin Normal Operation command, for example, requires use of the WSCMD command for a Revision 1.2 device, and the WSCMD? command for a Revision 1.3 device.

Example: WSCMD #H31 #HBC30<CR> <LF>

This command sends the VXIbus Byte Available command with a data value of 30 hex to the device at the logical address 31 hex.

Command: WSCMD? (Word Serial Protocol Command Query)

Syntax: WSCMD? LA CMD <CR> <LF>

Purpose: This command is used to send Word Serial Protocol commands that generate a response by the receiving device. The command sends the Word Serial Protocol command specified by 'CMD' to the VXI device specified by the Logical Address parameter (LA).

Description: LA the logical address (1 - 255) of the VXIbus device to receive the command, expressed in either ASCII decimal or ASCII hexadecimal notation. If an ASCII hex number is used, it must be preceded by '#H' or '#h'.

CMD the Word Serial Protocol command (as defined by the VXIbus Specification) to be sent to the logical device at address LA. The command and data can be expressed in either ASCII decimal or ASCII hex notation. If an ASCII hex number is used, it must be preceded by '#H' or '#h'.

If the referenced logical device does not exist, or is not a Message Based Device, or references the VX4520 IEEE device, an Invalid Logical Address error is generated. If the eight most significant bits of the command value do not correspond to a valid Word Serial command, an Invalid Command error is generated.

The effects of the command are not reflected in the Resource Manager's Configuration Array. Use this command only to send Word Serial commands that generate responses by the receiving VXI device. The response value is returned to the system controller the next time the system controller requests input from the VX4520. The response is formatted in ASCII decimal and terminated with <CR> <LF>. Use the WSCMD command to send Word Serial commands that do not generate responses.

NOTE: Some Word Serial Protocol commands that did not require a response in Revision 1.2 of the VXIbus Specification do require a response in Revision 1.3. This requires special attention when using WSCMD and WSCMD? commands. The Begin Normal Operation command, for example, requires use of the WSCMD command for a Revision 1.2 device, and the WSCMD? command for a Revision 1.3 device.

Example: WSCMD? 20 #HDEFF <CR> <LF>
xxxxx <CR> <LF>

This command sends the Byte Request command to the VXIbus device at logical address 20. The device returns a single value (represented by xxxxx) in response to the Byte Request command. The VX4520 converts that value to a 5 digit ASCII decimal value and returns it, followed by a <CR> <LF>.

Error Handling

When the VX4520 detects an operational error, it invokes an error message format routine that generates an appropriate ASCII message. The error message can be read when input is requested from the VX4520.

An error message will overwrite any command result data that may already be present in the buffer, except another error message. Successive error messages are stored in the buffer until the buffer becomes full. Once the buffer is full, subsequent error messages are lost. The error message buffer will hold approximately ten error messages.

Non-error message information will never overwrite error information. For example, suppose you send the HELP command to the VX4520. This command generates an ASCII message listing the commands accepted by the Resource Manager. Before reading the help information, send the VX4520 a command requesting the status of a non-existent VXI device. The resulting error message will overwrite the help information in the VX4520's message buffer.

The next time you input from the VX4520, you will receive the error message, not the results of the HELP command. If the opposite sequence were to occur (first the error, then the HELP command), the HELP command message will not be placed in the VX4520's message buffer because an error is pending that has not yet been read.

To aid in the detection of asynchronously occurring errors, the VX4520 may be programmed to generate IEEE-488 Service Requests whenever an error occurs. See the discussion on SRQ Operation.

The VX4520 error messages and their meanings are as follows:

- 1: VMEBus Error -
A VMEBus access was attempted, but no DTACK occurred.
- 2: Invalid Command Received -
User Interface Command syntax error.
- 3: VME BERR During IACK - Check Daisy Chain -
Indicates a break in the VXIbus daisy chained signals.
- 4: A24 Address Space Conflict -
The Resource Manager could not calculate a valid A24 memory reference when configuring the VXI memory allocation for a VXI device.
- 5: A32 Address Space Conflict -
The Resource Manager could not calculate a valid A32 memory reference when configuring the VXI memory allocation for a VXI device.
- 6: Invalid Logical Address Received -
A device does not exist at the referenced logical address, or no device of the correct type exists at that logical address.

- 7: 4520 Failed Self Test -
The VX4520 failed power-up self test, or failed the self test executed in response to the user interface command TEST.
- 8: Sysfail Asserted And Cannot Be Released -
The VXI signal SYSFAIL is being asserted and cannot be cleared by enabling the Sysfail Inhibit capability of each VXI device in the system.
- 9: Sysfail Asserted By Device At LA -
The specified device at decimal logical address LA asserted the VXI signal SYSFAIL. The device cleared the signal when the Resource Manager set the Sysfail Inhibit bit in the device's Control register.
- 11: Invalid IEEE Address Received -
Generated in response to an IEEE-488 bus address that is less than 1 or greater than 30.
- 12: Cannot Properly Detect All Cards In The Card Cage -
Generated during initialization when the Resource Manager detects a different number of cards in the mainframe than correspond to the driven MODID lines. This can occur for a number of reasons; for example:
- ▶ a foreign device is in the cage,
 - ▶ presence of a VXI device that does not drive the MODID lines,
 - ▶ two or more VXI devices are present in the system with the same logical address, or
 - ▶ presence of a multi-slot instrument driving the MODID lines of each slot it occupies.
- 13: Cannot Grant Servant Device At LA -
Generated during initialization if a commander's servant area encompasses a non-existent VXI device. LA represents the decimal logical address of the non-existent servant.
- 14: Device Is Not a Commander -
Generated during dynamic commander/servant hierarchy reconfiguration when a VXI device without commander capability is referenced.
- 15: Servant Does Not Belong To This Commander -
Generated during dynamic commander/servant hierarchy reconfiguration when an attempt is made to release a servant device from a commander device that is not currently the servant's commander.

- 16: **Servant Already Belongs To A Commander -**
Generated during dynamic commander/servant hierarchy reconfiguration when an attempt is made to grant a servant device to a commander device and that servant currently belongs to another commander.
- 18: **Device Does Not Support Programmable Interrupts -**
Generated during interrupter allocation when a device is referenced that does not have the programmable interrupter capability.
- 19: **Device Does Not Support Programmable Interrupt Handlers-**
Generated during interrupt handler allocation when a device is referenced that does not have programmable interrupt handler capability.
- 20: **Referenced Interrupt Handler Does Not Exist -**
Generated during interrupt handler allocation when a device handler is referenced that is greater than the number of handlers the device contains.
- 21: **Invalid VME IRQ Line Reference -**
Generated during VME Interrupt Request line allocation when the IRQ line is less than 0 or greater than 7.
- 22: **Device Does Not Support WSP Read Protocol Error Command -**
Generated when the user interface STATUS command is issued to a Message Based Device that does not support the Read Protocol Error WSP command.
- 26: **Device Has Not Passed Self Test -**
Generated when the user interface command BNO is issued to a device that has failed its self test.
- 27: **Device Has Sysfail Inhibited -**
Generated when the user interface command BNO is issued to a device that has the Sysfail Inhibit bit set in its Control register as a result of system diagnostics.
- 28: **Device Is In Reset State -**
Generated when the user interface command BNO is issued to a device that has the Reset bit set in its Control register.
- 29: **Dynamic Configuration Failure by Device in Slot -**
Generated during dynamic device configuration when the device cannot be successfully accessed at its dynamically assigned logical address. The device is identified by its slot location.
- 30: **Referenced Interrupter Does Not Exist -**
Generated during interrupter allocation when a device interrupt process is referenced that is greater than the number of interrupting processes the device contains.

- 100: Cmd = #h0000; LA = 000; Response = #h0000 -
Generated when a Word Serial Protocol error is detected by the VX4520. The #h0000 in the cmd field is replaced with the hex value of the actual Word Serial command that generated the error response. The 000 in the LA field is replaced by the logical address of the VXI device that was issued the Word Serial command. The #h0000 in the response field is replaced by the hex value of the error value generated.
- 101: Cmd = BNO; LA = 000; Response = #h0000 -
Generated when a Begin Normal Operation command is issued to a device, and the device's response indicates the BNO command was not successfully executed. The LA field indicates the logical address of the device that was issued the BNO command. The response field contains the response value returned by the device.
- 102: Cmd = Read Handlers; LA = 000; Response = #h0000 -
Generated during interrupt handler allocation when a device's response to the Read Handlers command returns an invalid value. The LA field indicates the logical address of the device that was issued the Read Handlers command. The response field contains the response value returned by the device.
- 103: Cmd = Read Interrupters; LA = 000; Response = #h0000 -
Generated during interrupter allocation when a device's response to the Read Interrupters command returns an invalid value. The LA field indicates the logical address of the device that was issued the Read Interrupters command. The response field contains the response value returned by the device.
- 104: Cmd = Set Handlers; LA = 000; Response = #h0000 -
Generated during interrupt handler allocation when a device's response to the Assign Handler Line command indicates the command was not successfully executed. The LA field indicates the logical address of the device that was issued the Assign Handler Line command. The response field contains the response value returned by the device.
- 105: Cmd = Set Interrupters; LA = 000; Response = #h0000 -
Generated during interrupter allocation when a device's response to the Assign Interrupter Line command indicates the command was not successfully executed. The LA field indicates the logical address of the device that was issued the Assign Interrupter Line command. The response field contains the response value returned by the device.
- 106: Cmd = ENO; LA = 000; Response = #h0000 -
Generated when an End Normal Operation command is issued to a device, and the device's response indicates the ENO command was not successfully executed. The LA field indicates the logical address of the device that was issued the ENO command. The response field contains the response value returned by the device.

- 107: Cmd = Release Device; LA = 000; Response = #h0000 -
Generated during dynamic commander/servant hierarchy reconfiguration when a device's response to the Release Device command indicates the command was not successfully executed. The LA field indicates the logical address of the device that was issued the Release Device command. The response field contains the response value returned by the device.
- 108: Cmd = SAS; LA = 000; Response = #h0000 -
Generated during dynamic commander/servant hierarchy reconfiguration when a device's response to the Read Servant Area command returns an invalid response. The LA field contains the logical address of the device that was issued the Read Servant Area command. The response field contains the response value returned by the device.
- 109: Unrecognized Command; LA = 000; Cmd Value = #h0000 -
Generated when a device is issued a Word Serial Protocol command and the device generates an Unrecognized Command interrupt or signal. The LA field contains the logical address of the device that was issued the command. The Cmd Value field contains the hex value of the command that was not recognized.
- 110: Cmd = Read Handler Line; LA = 000; Response = #h0000 -
Generated during interrupt handler allocation when a device's response to the Read Handler Line command indicates the command was not successfully executed. The LA field contains the logical address of the device that was issued the Read Handler Line command. The response field contains the response value returned by the device.
- 111: Invalid Device SubState; LA = 000; Cmd Value = #h0000 -
Generated when a device is issued a Word Serial command while the device is in the incorrect operational sub-state to execute the command; if, for example, a command only valid in Normal Operation state was issued to a device in Configuration state.
- 112: Cmd = Read Interrupter Line; LA = 000; Response = #h0000 -
Generated during interrupter allocation when a device's response to the Read Interrupter Line command indicates the command was not successfully executed. The LA field reflects the logical address of the device that was issued the Read Interrupter Line command. The response field contains the response value returned by the device.
- 113: Command Not Supported; LA = 000; Cmd Value = #h0000.
This error is returned when a device responds to a WSP command with the Command Not Supported error response. The LA field is the Logical Address of the device that generated the error. The Cmd Value field is the Word Serial Command that was not supported by the device.
- 114: IEEE Address Cannot Be Assigned To Device At LA: 000.
This error is generated when the Resource Manager is using the Shifting Algorithm to assign IEEE- 488 addresses to VXI devices and a device's Logical

Address can not be shifted to form a valid IEEE address. This is because the resulting IEEE address value would be less than 1 or greater than 30. Rather than being given an invalid IEEE-488 address, the device is not given any IEEE address. The device's Logical Address may be changed to a value between 8 and 240, or the MAP command may be used to assign the device an IEEE-488 address.

- 115: Cmd = Read STB; LA = 000; Response = #h0000 -
Generated when a device is issued the Read STB command and the device returns an invalid response. The LA field contains the logical address of the device that was issued the Read STB command. The response field contains the response value returned by the device.
- 116: Write Ready Timeout Error; LA = 000; Cmd Value = #h0000 -
Generated when the VX4520 attempts to issue a Word Serial Protocol command to a device, but the device's Response register never becomes write ready, and the command cannot be written. The LA field is the logical address of the device. The Cmd Value field contains the hex value of the command that could not be written.
- 117: Read Ready Timeout Error; LA = 000; Cmd Value = #h0000 -
Generated when the VX4520 attempts to read a WSP response value from a device, but the device's Response register never becomes read ready, and the response cannot be obtained. The LA field contains the logical address of the device. The Cmd Value field contains the hex value of the command whose response could not be read.
- 118: Both Rd & Wrt Rdy Timeout; LA = 000; Cmd Value = #h0000 -
Generated when the VX4520 attempts to issue a Word Serial Protocol command to a device, but the device's Response register never becomes read ready or write ready. The LA field contains the logical address of the device. The Cmd Value field contains the hex value of the command.
- 120: Unrecognized Event; LA = 000; Event = #h0000 -
Generated when the Resource Manager receives a VXI event it does not recognize. The LA field specifies the logical address of the VXI device that sent the event. The Event field specifies the unknown event value.
- 121: Unrecognized Event Src; LA = 000; Event = #h0000 -
Generated when the Resource Manager receives a VXI event from a source it does not recognize. That is, the logical address value of the VXI device event specifies a non-existent VXI device. The Event field specifies the event value.

Section 4

Programming Examples

This section contains example programs which demonstrate how the various programmable features of the VX4520 are used. The examples are written in BASIC using an IBM PC or equivalent computer as the system controller.

Definition of BASIC Commands

The programming examples in this manual are written in Microsoft GW BASIC, using the GW BASIC commands described below. If the programming language you are using does not conform exactly to these definitions, use the command in that language that will give the same result.

<u>Command</u>	<u>Result</u>
CALL ENTER (R\$, LENGTH%, ADDRESS%, STATUS%)	The CALL ENTER statement inputs data into the string R\$ from the IEEE-488 instrument whose decimal primary address is contained in the variable ADDRESS%. Following the input, the variable LENGTH% contains the number of bytes read from the instrument. The variable STATUS% contains the number '0' if the transfer was successful or an '8' if an operating system timeout occurred in the PC. Prior to using the CALL ENTER statement, the string R\$ must be set to a string of spaces whose length is greater than or equal to the maximum number of bytes expected from the VX4520.
CALL SEND (ADDRESS%, WRT\$, STATUS%)	The CALL SEND statement outputs the contents of the string variable WRT\$ to the IEEE-488 instrument whose decimal primary address is contained in the variable ADDRESS%. Following the output of data, the variable STATUS% contains a '0' if the transfer was successful and an '8' if an operating timeout occurred in the PC.
END	Terminates the program.
FOR/NEXT	Repeats the instructions between the FOR and NEXT statements for a defined number of iterations.
GOSUB n	Runs the subroutine beginning with line n. EX: GOSUB 750 - runs the subroutine beginning on line 750. The end of the subroutine is delineated with a RETURN statement. When the subroutine reaches the RETURN statement, execution will resume on the line following the GOSUB command.

GOTO n	Program branches to line n. EX: GOTO 320 - directs execution to continue at line 320.
IF/THEN	Sets up a conditional IF/THEN statement. Used with other commands, such as PRINT or GOTO, so that IF the stated condition is met, THEN the command following is effective. EX: IF I = 3 THEN GOTO 450 - will continue operation at line 450 when the value of variable I is 3.
REM	All characters following the REM command are not executed. REM statements are used for documentation and user instructions. EX: REM **CLOSE ISOLATION RELAYS**
RETURN	Ends a subroutine and returns operation to the line after the last executed GOSUB command.
<CR>	Carriage Return character, decimal 13.
<LF>	Line Feed character, decimal 10.

Programming Examples In BASIC

The following sample BASIC programs show how commands for the VX4520 might be used. These examples assume that the VX4520 has logical address 1 and is installed in a VXibus mainframe that is controlled through an IEEE-488 interface from an external system controller, such as an IBM PC or equivalent using a Capital Equipment Corp. IEEE-488 interface.

Following each example, the data sent to and returned from the module is shown, with data returned by the module shown underlined.

Example 1:

The following program sends the TABLE command to the VX4520 and then reads back the system configuration.

Lines 10 through 40 initialize the PC's IEEE-488 interface card as a system controller with an IEEE-488 address of decimal 21. Line 50 assigns the decimal IEEE-488 address of the VX4520 to the variable ADDR4520%.

```
10 GOSUB 1000
20 SEND = 9 : INIT = 0 : ENTER = 21
30 PC.ADDRESS% = 0 : CONTROL% = 0
40 CALL INIT(PC.ADDRESS%, CONTROL%)
50 ADDR4520% = 1
```

```
100 S$ = "TABLE"
110 CALL SEND(ADDR4520%, S$, STATUS%)
120 IF STATUS% <> 0 THEN PRINT "ERROR " STATUS% :STOP

200 R$ = SPACE$(100)
210 FOR I = 1 TO 12
220   CALL ENTER(R$, LENGTH%, ADDR4520%, STATUS%)
230   IF STATUS% <> 0 THEN PRINT "ERROR " STATUS% :STOP
240   PRINT LEFT$(R$,LENGTH%)
250 NEXT I

1000 FOR I = &H40 TO &HEC STEP &H4
1010 FAILED = 0: DEF SEG = (I * &H100)
1020 IF CHR$(PEEK (50) ) <> "C" THEN FAILED = 1
1030 IF CHR$(PEEK (51) ) <> "E" THEN FAILED = 1
1040 IF CHR$(PEEK (52) ) <> "C" THEN FAILED = 1
1050 IF FAILED = 0 THEN CECLOC = (I* &H100): I= &HEC
1060 NEXT I
1070 RETURN
```

Section 4

Appendix A

VXIbus Operation

CAUTION

If the user's card cage has other manufacturer's computer boards operating in the role of VXIbus foreign devices, the assertion of BERR (as defined by the VXIbus Specification) may cause operating problems on these boards.*

Word Serial Protocol

The VX4520 supports the Normal Transfer Mode of the VXIbus, using the Write Ready and Read Ready bits of its servant's Response register.

A Normal Transfer mode read of the VX4520's servant module proceeds as follows:

1. The VX4520 reads the servant's Response register and checks if the Write Ready bit is true. If it is, the VX4520 proceeds to the next step. If not, the VX4520 continues to poll the Write Ready bit until it becomes true.
2. The VX4520 writes the Byte Request command (0DEFFh) to the servant's Data Low register.
3. The VX4520 reads the servant's Response register and checks if the Read Ready bit is true. If it is, the VX4520 proceeds to the next step. If not, the VX4520 continues to poll the Read Ready bit until it becomes true.
4. The VX4520 reads the servant's Data Low register.
5. The VX4520 will then place the data byte received from the servant on the IEEE-488 bus.

A Normal Transfer mode write to a VX4520's servant module proceeds as follows:

1. A byte of data is sent on the IEEE-488 bus.
2. The VX4520 reads the servant's Response register and checks if the Write Ready bit is true. If it is, the VX4520 proceeds to the next step. If not, the VX4520 continues to poll the Write Ready bit until it becomes true.

3. The VX4520 writes the Byte Available command which contains the data (OBCXX or OBDXX depending on the state of the End bit) to the servant's Data Low register.

Fast Handshake Protocol

The VX4520 also supports the Fast Handshake protocol defined by VXI. If the module has the FHS Capable bit in the Protocol register set to 0 (active) during the power up sequence, then data transfers take place as follows:

FHS READS from a module -

1. The VX4520 checks the FHS Active bit in the Response register. If the bit is set to 0, then the VX4520 enters the Fast Handshake Mode for all transfers until the module asserts Bus Error.
2. The VX4520 sends the Byte Request command to the Data Low register.
3. The VX4520 reads the Data Low register and sends data to the IEEE-488 bus.
4. If the Bus Error occurs while sending the Byte Request, then the VX4520 will begin polling the Write Ready bit before once again sending the Byte Request command to the Data Low register.

If the Bus Error occurs while the VX4520 is reading the Data Low register, then the VX4520 will NOT send the data it read from the module to the IEEE-488 bus. Instead, it will begin polling the Read Ready bit and when it become true, the VX4520 will read the Data Low register. The data from that read will be sent to the IEEE-488 bus.

5. Once the module asserts Bus Error, the VX4520 will return to the normal Word Serial Protocol mode of using the Write Ready and Read Ready bits for data transfers. The module may set the FHS Active bit to 0 again at any time.

FHS WRITES to a module -

1. The VX4520 checks the FHS Active bit in the Response register. If the bit is set to 0, then the VX4520 enters the Fast Handshake mode for all transfers until the module asserts Bus Error.
2. The VX4520 sends the Byte Available command which contains the data to the Data Low register.
3. If or when the Bus Error occurs, the VX4520 will NOT send the data it read from the IEEE-488 bus to the module until the module's Write Ready bit becomes true.

4. Once the module asserts Bus Error, the VX4520 will return to the normal Word Serial Protocol mode of using the Write Ready and Read Ready bits for data transfers. The module may set the FHS Active bit to 0 again at any time.

Appendix B

Input/Output Connections

P4 FRONT CONNECTOR PIN ASSIGNMENTS

<u>Signal</u>		<u>VX4520 P4 Connector Pin No.</u>
ATN	ATTENTION	11
GND	GROUND	23
SRQ	SERVICE REQUEST	10
GND	GROUND	22
NDAC	NOT DATA ACCEPTED	8
GND	GROUND	20
NRFD	NOT READY FOR DATA	7
GND	GROUND	19
DAV	DATA AVAILABLE	6
GND	GROUND	18
IFC	INTERFACE CLEAR	9
GND	GROUND	21
EOI	END OR IDENTIFY	5
REN	REMOTE ENABLE	17
DI01	DATA INPUT/OUTPUT 1	1
DI02	DATA INPUT/OUTPUT 2	2
DI03	DATA INPUT/OUTPUT 3	3
DI04	DATA INPUT/OUTPUT 4	4
DI05	DATA INPUT/OUTPUT 5	13
DI06	DATA INPUT/OUTPUT 6	14
DI07	DATA INPUT/OUTPUT 7	15
DI08	DATA INPUT/OUTPUT 8	16
LOGIC GROUND		12
SHIELD		12

Appendix C

VXI Glossary

The terms in this glossary are defined as used in the VXIbus System. Although some of these terms may have different meanings in other systems, it is important to use these definitions in VXIbus applications. Terms which apply only to a particular instrument module are noted. Not all terms appear in every manual.

Term	Definition
Accessed Indicator	An amber LED indicator that lights when the module identity is selected by the Resource Manager module, and flashes during any I/O operation for the module.
ACFAIL *	A VMEbus backplane line that is asserted under these conditions: 1) by the card cage Power Supply when a power failure has occurred (either ac line source or power supply malfunction), or 2) by the front panel ON/STANDBY switch when switched to STANDBY.
A-Size Card	A VXIbus instrument module that is 100.0 by 160 mm by 20.32 mm (3.9 by 6.3 in by 0.8 in), the same size as a VMEbus single-height short module.
Asynchronous Communication	Communications that occur outside the normal "command-response" cycle. Such communications have higher priority than synchronous communication.
Backplane	The printed circuit board that is mounted in a VXIbus card cage to provide the interface between VXIbus modules and between those modules and the external system.
B-Size Card	A VXIbus instrument module that is 233.4 by 160 mm by 20.32 mm (9.2 by 6.3 in by 0.8 in), the same size as a VMEbus double-height short module.
Bus Arbitration	In the VMEbus interface, a system for resolving contention for service among VMEbus Master devices on the VMEbus.
Bus Timer	A functional module that measures the duration of each data transfer on the Data Transfer Bus (DTB) and terminates the DTB cycle if the duration is excessive. Without the termination capability of this module, a Bus Master attempt to transfer data to or from a non-existent Slave location could result in an infinitely long wait for the Slave response.

Client	In shared memory protocol (SMP), that half of an SMP channel that does not control the shared memory buffers.
CLK10	A 10-MHz, ± 100 ppm, individually buffered (to each module slot), differential ECL system clock that is sourced from Slot 0 and distributed to Slots 1-12 on P2. It is distributed to each module slot as a single source, single destination signal with a matched delay of under 8 ns.
CLK100	A 100-MHz, ± 100 ppm, individually buffered (to each module slot), differential ECL system clock that is sourced from Slot 0 and distributed to Slots 1-12 on P3. It is distributed to each module slot in synchronous with CLK10 as a single source, single destination signal with a maximum system timing skew of 2 ns, and a maximum total delay of 8 ns.
Commander	In the VXIbus interface, a device that controls another device (a servant). A commander may be a servant of another commander.
Command	<p>A directive to a device. There are three types of commands:</p> <p>In Word Serial Protocol, a 16-bit imperative to a servant from its commander.</p> <p>In Shared Memory Protocol, a 16-bit imperative from a client to a server, or vice versa.</p> <p>In a Message, an ASCII-coded, multi-byte directive to any receiving device.</p>
Communication Registers	In word serial protocol, a set of device registers that are accessible to the commander of the device. Such registers are used for inter-device communications, and are required on all VXIbus message-based devices.
Configuration Registers	A set of registers that allow the system to identify a (module) device type, model, manufacturer, address space, and memory requirements. In order to support automatic system and memory configuration, the VXIbus standard specifies that all VXIbus devices have a set of such registers, all accessible from P1 on the VMEbus.
C-Size Card	A VXIbus instrument module that is 340.0 by 233.4 mm by 30.48 mm (13.4 by 9.2 in by 1.2 in).
Custom Device	A special-purpose VXIbus device that has configuration registers so as to be identified by the system and to allow for definition of future device types to support further levels of compatibility.

Data Transfer Bus	One of four buses on the VMEbus backplane. The Data Transfer Bus allows Bus Masters to direct the transfer of binary data between Masters and Slaves.
DC SUPPLIES Indicator	A red LED indicator that illuminates when a DC power fault is detected on the backplane.
Device Specific Protocol	A protocol for communication with a device that is not defined in the VXIbus specification.
D-Size Card	A VXIbus instrument module that is 340.0 by 366.7 mm by 30.48 mm (13.4 x 14.4 in x 1.2 in).
DTB	See Data Transfer Bus.
DTB Arbiter	A functional module that accepts bus requests from Requester modules and grants control of the DTB to one Requester at a time.
DUT	Device Under Test.
ECLTRG	Six single-ended ECL trigger lines (two on P2 and four on P3) that function as inter-module timing resources, and that are bussed across the VXIbus subsystem backplane. Any module, including the Slot 0 module, may drive and receive information from these lines. These lines have an impedance of 50 ohms; the asserted state is logical High.
Embedded Address	An address in a communications protocol in which the destination of the message is included in the message.
ESTST	Extended Start/Stop protocol; used to synchronize VXIbus modules.
Extended Self Test	Any self test or diagnostic power-up routine that executes after the initial kernel self test program.
External System Controller	The host computer or other external controller that exerts overall control over VXIbus operations.
FAILED Indicator	A red LED indicator that lights when a device on the VXIbus has detected an internal fault. This might result in the assertion of the SYSFAIL* line.
IACK Daisy Chain Driver	The circuit that drives the VMEbus Interrupt Acknowledge daisy chain line that runs continuously through all installed modules or through jumpers across the backplane.

ID-ROM	An NVRAM storage area that provides for non-volatile storage of diagnostic data.
Instrument Module	A plug-in printed circuit board, with associated components and shields, that may be installed in a VXIbus card cage. An instrument module may contain more than one device. Also, one device may require more than one instrument module.
Interface Device	A VXIbus device that provides one or more interfaces to external equipment.
Interrupt Handler	A functional module that detects interrupt requests generated by Interrupters and responds to those requests by requesting status and identity information.
Interrupter	A device capable of asserting VMEbus interrupts and performing the interrupt acknowledge sequence.
IRQ	The Interrupt ReQuest signal, which is the VMEbus interrupt line that is asserted by an Interrupter to signify to the controller that a device on the bus requires service by the controller.
Local Bus	A daisy-chained bus that connects adjacent VXIbus slots.
Local Controller	The instrument module that performs system control and external interface functions for the instrument modules in a VXIbus card cage or several card cages. See Resource Manager.
Local Processor	The processor on an instrument module.
Logical Address	The smallest functional unit recognized by a VXIbus system. It is often used to identify a particular module.
Mainframe	Card Cage For example, the Tektronix VX1400 Card Cage, an operable housing that includes 13 C-size VXIbus instrument module slots.
Memory Device	A storage element (such as bubble memory, RAM, and ROM) that has configuration registers and memory attributes (such as type and access time).
Message	A series of data bytes that are treated as a single communication, with a well defined terminator and message body.
Message Based Device	A VXIbus device that supports VXI configuration and communication registers. Such devices support the word serial protocol, and possibly other message-based protocols.

MODID Lines	Module/system identity lines.
Physical Address	The address assigned to a backplane slot during an access.
Power Monitor	A device that monitors backplane power and reports fault conditions.
P1	The top-most backplane connector for a given module slot in a vertical card cage such as the Tektronix VX1400. The left-most backplane connector for a given slot in a horizontal card cage.
P2	The bottom backplane connector for a given module slot in a vertical C-size card cage such as the VX1400; or the middle backplane connector for a given module slot in a vertical D-size card cage such as the VX1500.
P3	The bottom backplane connector for a given module slot in a vertical D-size card cage such as the Tektronix VX1500.
Query READY Indicator	<p>A form of command that allows for inquiry to obtain status or data.</p> <p>A green LED indicator that lights when the power-up diagnostic routines have been completed successfully. An internal failure or failure of +5-volt power will extinguish this indicator.</p>
Register Based Device	A VXIbus device that supports VXI register maps, but not high level VXIbus communication protocols; includes devices that are register-based servant elements.
Requester	A functional module that resides on the same module as a Master or Interrupt Handler and requests use of the DTB whenever its Master or Interrupt Handler requires it.
Resource Manager	A VXIbus device that provides configuration management services such as address map configuration, determining system hierarchy, allocating shared system resources, performing system self test diagnostics, and initializing system commanders.
Self Calibration	A routine that verifies the basic calibration of the instrument module circuits, and adjusts this calibration to compensate for short- and long-term variables.
Self Test	A set of routines that determine if the instrument module circuits will perform according to a given set of standards. A self test routine is performed upon power-up.
Servant	A VXIbus message-based device that is controlled by a commander.

Server	A shared memory device that controls the shared memory buffers used in a given Shared Memory Protocol channel.
Shared Memory Protocol	A communications protocol that uses a block of memory that is accessible to both client and server. The memory block operates as a message buffer for communications.
Slot 0 Controller	See Slot 0 Module. Also see Resource Manager.
Slot 0 Module	A VXIbus device that provides the minimum VXIbus slot 0 services to slots 1 through 12 (CLK10 and the module identity lines), but that may provide other services such as CLK100, SYNC100, STARBUS, and trigger control.
SMP	See Shared Memory Protocol.
STARX	Two (2) bi-directional, 50 ohm, differential ECL lines that provide for inter-module asynchronous communication. These pairs of timed and matched delay lines connect slot 0 and each of slots 1 through 12 in a card cage. The delay between slots is less than 5 nanoseconds, and the lines are well matched for timing skew.
STARY	Two (2) bi-directional, 50 ohm, differential ECL lines that provide for inter-module asynchronous communication. These pairs of timed and matched delay lines connect slot 0 and each of slots 1 through 12 in a card cage. The delay between slots is less than 5 nanoseconds, and the lines are well matched for timing skew.
STST	STart/STop protocol; used to synchronize modules.
SYNC100	A Slot 0 signal that is used to synchronize multiple devices with respect to a given rising edge of CLK100. These signals are individually buffered and matched to less than 2ns of skew.
Synchronous Communications	A communications system that follows the "command-response" cycle model. In this model, a device issues a command to another device; the second device executes the command; then returns a response. Synchronous commands are executed in the order received.
SYSFAIL*	A signal line on the VMEbus that is used to indicate a failure by a device. The device that fails asserts this line.
System Clock Driver	A functional module that provides a 16-MHz timing signal on the Utility Bus.
System Hierarchy	The tree structure of the commander/servant relationships of all devices in the system at a given time. In the VXIbus structure, each

	servant has a commander. A commander may also have a commander.
Test Monitor	An executive routine that is responsible for executing the self tests, storing any errors in the ID-ROM, and reporting such errors to the Resource Manager.
Test Program	A program, executed on the system controller, that controls the execution of tests within the test system.
Test System	A collection of hardware and software modules that operate in concert to test a target DUT.
TTLTRG	Open collector TTL lines used for inter-module timing and communication.
VXIbus Subsystem	One card cage with modules installed. The installed modules include one module that performs slot 0 functions and a given complement of instrument modules. The subsystem may also include a Resource Manager.
Word Serial Protocol	A VXIbus word oriented, bi-directional, serial protocol for communications between message-based devices (that is, devices that include communication registers in addition to configuration registers).
Word Serial Communications	Inter-device communications using the Word Serial Protocol.
WSP	See Word Serial Protocol.
10-MHz Clock	A 10 MHz, ± 100 ppm timing reference. Also see CLK10.
100-MHz Clock	A 100 MHz, ± 100 ppm clock synchronized with CLK10. Also see CLK100.
488-To-VXIbus Interface	A message based device that provides for communication between the IEEE-488 bus and VXIbus instrument modules.

Appendix D

Shifting Method

If the IEEE Mapping Algorithm switch (position 3 of the Configuration switches) is set open, the shifting method described in this appendix is used to assign the IEEE-488 address as a function of the device's logical address.

The IEEE-488 address of the VX4520 is determined by the upper five bits of the logical address. The lower three bits should be set to 0. This same mapping algorithm is used to establish the IEEE-488 primary address of the instruments in the system. For example:

Module Logical Address (Hex) (Decimal)		IEEE-488 Primary Address (Decimal)
08	8	1
10	16	2
18	24	3
78	120	15
C0	192	24

If an instrument (or instrument set) occupies more than one logical address, the IEEE-488 address only applies to the instrument's commander device. The other devices's logical addresses should have the upper five bits set identical to the commander's upper five bits, and the lower three bits should be incremented for each additional device. For example, in the following system, slots 1, 2, and 3 are a three card instrument set:

Device	Logical Address	IEEE-488 Address
VX4520	18h	3
Slot 1	08h	1
Slot 2	09h	N/A
Slot 3	0Ah	N/A
Slot 4	50h	10
Slot 5	88h	17
.	.	.
.	.	.
.	.	.

IEEE-488 addresses 0 and 31 should not be used.

IEEE-488 Single Primary/Multiple Secondary Address Mapping

When Configuration switch position 1 is set closed, IEEE-488 addresses are translated to VXibus logical addresses as described below.

The IEEE-488 primary address for all instruments in the mainframe and for the VX4520 is determined by the setting of the two hexadecimal rotary switches on the VX4520 Module.

The IEEE-488 secondary address of the VX4520 and the IEEE-488 primary address for all instruments in the system are determined by the upper five bits of the logical address. The lower three bits should be set to 0. This same mapping algorithm is used to establish the IEEE-488 secondary address of the instruments in the system. For example:

Module Logical Address (Hex) (Decimal)		IEEE-488 Secondary Address (Decimal)
08	8	1
10	16	2
18	24	3
78	120	15
C0	192	24

If an instrument (set) occupies more than one logical address, the IEEE-488 address only applies to the instrument's commander device. The other devices's logical addresses should have the upper five bits set identical to the commander's upper five bits, and the lower three bits should be incremented for each additional device. For example, in the following system, slots 1, 2, and 3 are a three card instrument set:

Device	Logical Address	IEEE-488 Primary Address	IEEE-488 Secondary Address
VX4520	18h	3	3
Slot 1	08h	3	1
Slot 2	09h	N/A	N/A
Slot 3	0Ah	N/A	N/A
Slot 4	50h	3	10
Slot 5	88h	3	17
.	.	.	.
.	.	.	.
.	.	.	.

IEEE-488 primary addresses 0 and 31 should not be used. IEEE-488 secondary addresses 0, 30, and 31 should not be used.